



Efficient Energy Automation with the IEC 61850 Standard Application Examples

Energy Automation

Answers for energy.

SIEMENS

Efficient Energy Automation with the IEC 61850 Standard

Meet the standard
IEC 61850



2006
FROST & SULLIVAN
Technology Leadership Award

The IEC 61850 standard has been defined in cooperation with manufacturers and users to create a uniform, future-proof basis for the protection, communication and control of substations. In this brochure, we present some application examples and implemented stations with the new IEC 61850 communication standard. IEC 61850 already has an excellent track record as the established communication standard on the worldwide market for the automation of substations.

Its chief advantages are:

- **Simple substation structure:** No more interface problems. With IEC 61850, protocol diversity and integration problems are a thing of the past.
- **Everything is simpler:** From engineering to implementation, from operation to service. Save time and costs on configuration, commissioning and maintenance.
- **Reduction of costs:** IEC 61850 replaces wiring between feeders, control switches, and signaling devices.
- **More reliability:** You only use one communication channel for all data – in real time, synchronized via Ethernet.

Why use IEC 61850 technology from Siemens?

Siemens is the global market leader in this area. For you, that means: You benefit from the experience of projects for more than 1000 substations and 140000 protection devices implemented in accordance with the IEC 61850 communication standard by the end of 2010. Siemens offers you IEC 61850 technology that is certified as Class A by the independent testing laboratory KEMA. Future-proof investment due to convincing migration concepts: SIPROTEC 4 protection devices manufactured since 1998 can be upgraded to make them IEC 61850-compatible without any problem. The solutions from the SICAM 1703 and SICAM PAS product lines offer you flexible configurations for seamlessly integrating the latest IEC 61850 concepts into existing substations.

While reading this brochure, discover the diverse efficiency potential of energy automation with the IEC 61850 worldwide communication standard.

Choose a Powerful Partnership Energy Automation from Siemens

Ingo Erkens
General Manager
Energy Sector
Power Distribution Division
Energy Automation Products

Efficient Energy Automation with the IEC 61850 Standard Application Examples

Content

	Page
<i>Switchgear Interlocking with IEC 61850-GOOSE</i>	3
<i>Reverse Interlocking Using the GOOSE of IEC 61850</i>	7
<i>Beneficial Engineering of IEC 61850 Substation Automation Systems</i>	13
<i>Innovative Solutions for Substation Control with IEC 61850</i>	21
<i>Seamless Migration</i>	27
<i>Ethernet Topologies with IEC 61850</i>	31
<i>IEC Interoperability, Conformance and Engineering Experiences</i>	37
<i>IEC Browser – A Powerful Test Tool for IEC 61850</i>	43

Switchgear Interlocking with IEC 61850-GOOSE

1. Introduction

Fast communication directly between protection devices and bay control units according to IEC 61850-GOOSE can be used to implement switchgear interlocking across bays (substation interlocking). GOOSE stands for “generic object-oriented substation event” and is an especially fast communication service that functions independently of communication between the server (bay control unit) and client (centralized station controller).

And, as the system configurator software provides a view across devices, simple engineering of the substation interlocking is possible independent from the station level.

2. Task

In the simple example described here, the coupler and the two feeders of a double busbar system exchange the information necessary for substation interlocking (Fig. 1).

The information to be exchanged for substation interlocking are the following:

- 1) From the coupler to the feeders:
Information that the coupler is closed.

If this condition is met, the disconnectors may always be operated in the feeder bays (even if the circuit-breakers of the feeders are closed).

- 2) From the feeders to the coupler:
Information that the busbars are connected via the disconnectors. As soon as the two busbar disconnectors are closed in at least one bay, coupler C02 can no longer be opened because otherwise it would no longer be permissible to operate the disconnectors in the feeders. This function is called a coupler switch blocking. Each feeder sends this information to the coupler bay.

3. Solution with SIPROTEC and DIGSI

Configuration of the substation interlocking is best performed in four steps:

- 1) Creation in the DIGSI matrix of the additional GOOSE information items that are required

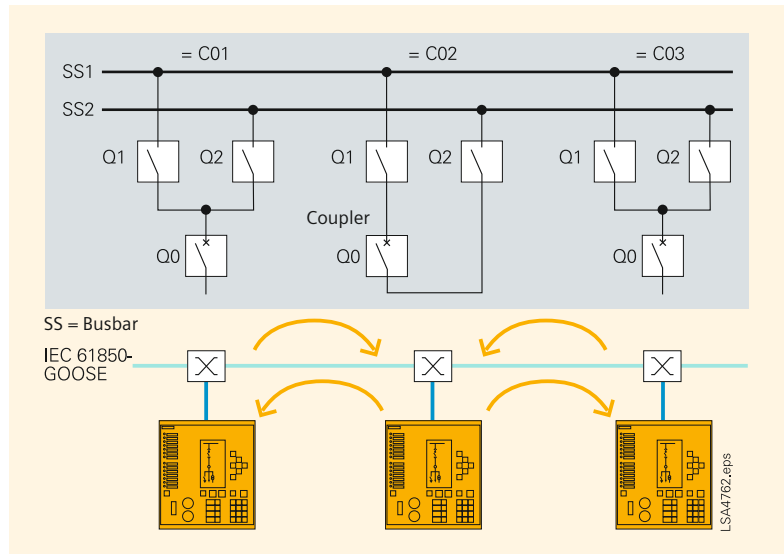

Fig. 1 Double busbar system with 2 feeders

- 2) Preparation of the CFC charts for generating the new messages and adding to the CFC charts for the switchgear interlocking
- 3) Creation of the IEC 61850 substation and configuration of communication (defining GOOSE subscribers, assigning IP addresses, creating the GOOSE application)
- 4) Routing of the GOOSE information items of the subscribers

In the first step, it is expedient to look at the single-line diagram (Fig. 1). This is the substation view and definition of the information transmitted and received by the devices. In our simple example, the following information is required in the three bays:

C01: Transmitted information:
Both busbar disconnectors in bay C01 closed

Received information:
Coupler closed

C02: Transmitted information:
Coupler closed

Received information:
Busbar disconnectors in bay C01 closed
Busbar disconnectors in bay C03 closed

C03: Transmitted information:
Both busbar disconnectors in bay C03 closed

Received information:
Coupler closed

These information items are created in a new group called “GOOSE” in the DIGSI matrix (see Fig. 2 on the following page, example of the coupler unit in C02).

Device	Number	Display text	Information	Long text	Type	Source		Destination											
						DI	BO	LE	Buffer				S				D		
									O	S	T	w	C	D	C	D	DI		
Control Device		Breaker	Breaker		CP_D12		X												
		Breaker	Breaker		OP								X	X	X	X			
		Q0 Op/Cr+	Q0 operation counter+		V+														
		Dis. Smk	Disconnect Switch		CP_D2		X												
		Dis. Smk	Disconnect Switch		OP								X	X	X	X			
		Q1 Op/Cr+	Q1 operation counter+		V+														
		Q2 ON/OFF	Disconnecter Q2		CP_D2		X												
		Q2 ON/OFF	Disconnecter Q2		OP								X	X	X	X			
		Q2 Op/Cr+	Q2 Operation Counter+		V+														
		Q2 Release	Interlocking Release CB G0		IntSP														
		Q1 Release	Interlocking Release DC Q1		IntSP														
		Q2 Release	Interlocking Release DC Q2		IntSP														
		Interlock1	Interlock data transmission sig 01		IntSP														
GOOSE		CO1SSDCls	C01 Busbar Disconnecter closed		E+SP		X												
		CO3SSDCls	C03 Busbar Disconnecter closed		E+SP														
		CO1CCouplC	C01 Coupler Closed		SP														

Fig. 2 GOOSE information items in the DIGSI matrix (example of coupler CO2).

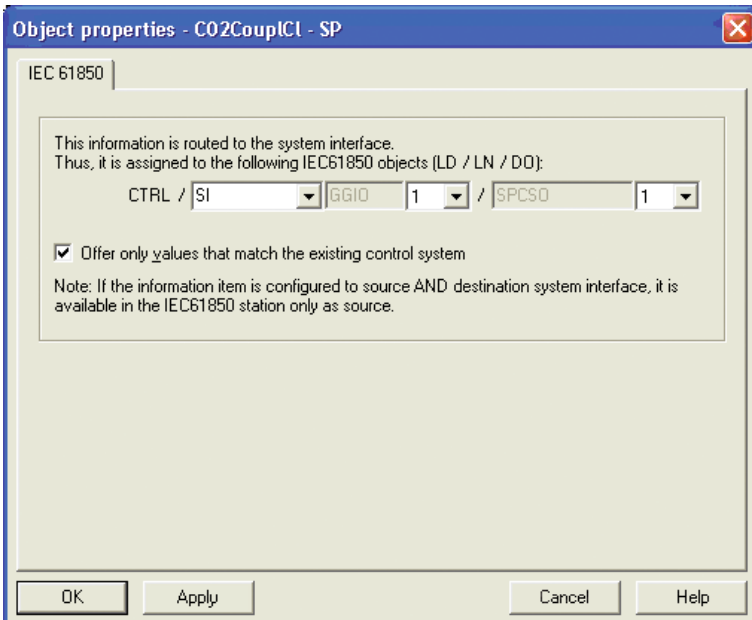

Fig. 3 Query dialog box for newly created IEC 61850 information items



Fig. 4 "IEC 61850 substation" icon in the DIGSI 4 manager

The GOOSE information items each have "CFC" as their source and the "system interface" as their destination. Placing a cross in the "System interface" destination column causes DIGSI to ask for the logical node name in the IEC 61850 designation. A meaningful abbreviation can be entered at this point, e.g. "SI" for switchgear interlocking (Fig. 3).

If the simple CFC charts for forming the information items "Coupler closed" and/or "Busbar disconnectors in Bay C01/C03 closed" have been created, the CFC charts can also be added for the switchgear interlocking (second step). This is done by including the additional information in the release of the busbar disconnectors (bays C01 and C03) and/or the coupler circuit-breaker (bay C02).

The third step is to close the DIGSI device engineering and create an IEC 61850 substation. This is done in the DIGSI manager in the same way as creating a device. A new "house" icon appears with the text "IEC 61850 substation" (Fig. 4).

This icon can be used to start the system configurator, which manages the IP addresses of the subscribers and permits configuration of the GOOSE communication. First, the subscribers of the GOOSE communication are defined. For this purpose, the substation is opened with the right mouse button (via "Object properties") and the "Subscribers" tab is selected (see Fig. 5 on the following page).

The upper area shows all available devices that can be moved into the lower area with the arrow button. In this way, multiple GOOSE units can be defined in one DIGSI project to keep configuration of the connections simple. This is achieved by creating a new IEC 61850 substation several times.

The IEC 61850 substation can then be opened with a double click on the house icon. This takes you to the system configurator with the two views "Network" and "Connection". Under "Network", the IP addresses are assigned and under "Connection" (Fig. 6), the GOOSE information items are connected, as in the DIGSI 4 matrix.

Bottom left and right, the GOOSE subscribers are listed in the two windows "Sources" and "Destinations". In the "Name" column, the IEC 61850 structure of the objects is visible and in the "Description" column, you can see the SIPROTEC texts. Under the logical device "Control", you will find in device C02 the logical node "SFSGGIO1" with the element "C02 coupler closed". You insert this in the upper "Connections" table using the "Add source" button. In the bottom right window "Destinations", you then choose the two corresponding information items that have the same name in devices C01 and C03 and move these to the "Destination" column. The connection of these information items is now stored in the system.

In the same way, the information items "Busbar disconnecter closed" from the feeder units are routed to the coupler. After this, the system configurator can be re-closed. As soon as the device parameter sets have been updated (triggered on the "Update" tab of the window in Fig. 5), the device parameter sets can be loaded. This update causes the GOOSE information to be written into the parameter sets.

After that, the parameters sets can be loaded into the SIPROTEC devices in the usual way. Again using a right mouse click on the substation, "Export IEC 61850 substation" can now be selected. The SCD file is then stored with all information for IEC 61850 communication. This can then be imported by a client, for example SICAM PAS. In our example, only the information report is routed to the client via the interface; the information required for the interlocking across bays is handled solely directly between the devices using GOOSE.

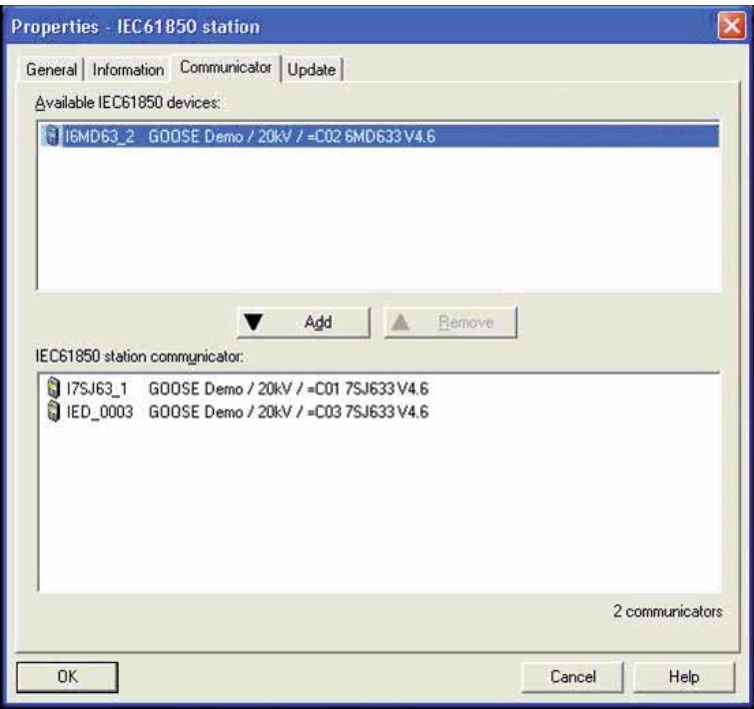

Fig. 5 Selection of the subscribers of a IEC 61850 substation

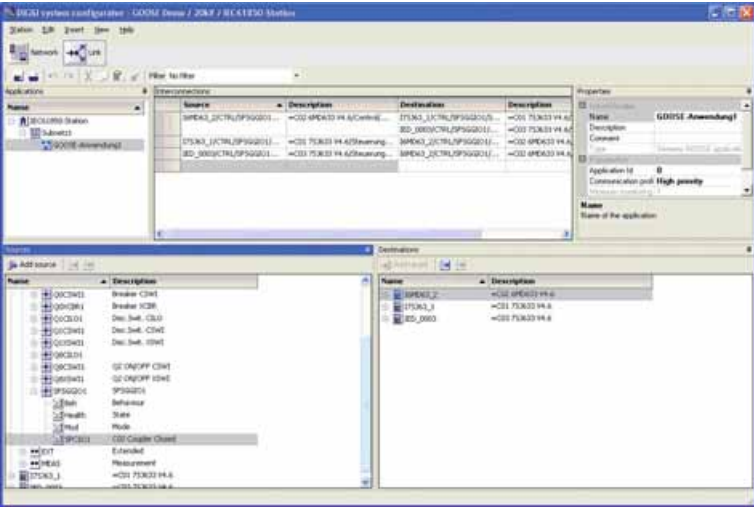

Fig. 6 "Connection" view in the system configurator

■ 4. Monitoring concept

Because GOOSE communication transmits safety-relevant data for switchgear interlocking (and also for the reverse interlocking of protection devices), monitoring of the connection is necessary.

This monitoring must

- Reliably detect and report a failure of the communication line
- Work selectively, i.e. only report information items as faulty that can really no longer be transmitted.

For this purpose, monitoring is performed at two points in the system: first, at each Ethernet channel, monitoring has the task of checking whether a connection to a switch exists. This also enables detection of failure of one channel in redundant communication, while communication is running via the second channel. For example, it is possible to take remedial action in time and maintain availability.

Second, the status of an information item can be evaluated. If the required communication channel is interrupted, the bit "NV" for "not valid" is set. This example illustrates this with the assumption that the connection between C01 and C02 has been interrupted (Fig. 7).

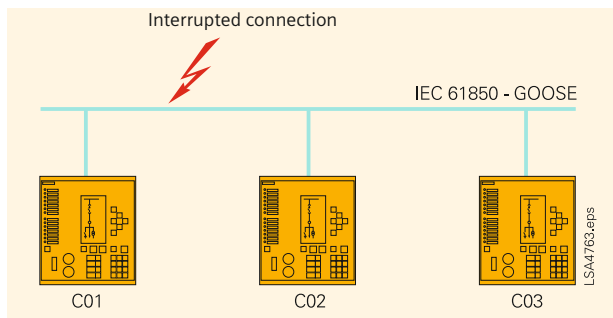

Fig. 7 Interrupted connection between 2 devices

In this case, the following information is invalid:

- "Coupler closed" in device C01
- "Busbar disconnector in bay C01 closed" in coupler C02

Additionally, the interrupted connections are shown in devices C01 and C02 ("Channel 1 faulty").

The devices C02 and C03, on the other hand, can continue to communicate undisturbed.

In this fault case, it must be ensured that these interlocking conditions that process the non-available information remain blocked. This is done by including the status in these conditions. The status can be obtained from the information items with the status CFC blocks in DIGSI 4 and then evaluated in the interlocking conditions.

■ 5. Summary

The use of IEC 61850-GOOSE enables implementation of "substation wide switchgear interlocking" as a distributed application. This has the advantage of independence from a centralized station controller and increased availability. This example shows how wiring between bay control units is replaced easily and reliably by GOOSE-telegrams. In various projects around the world, Siemens has successfully implemented this concept. Standardization of the IEC 61850 interface also makes it possible to build up interoperable solutions. In the GOOSE network, information can be exchanged between equipment of different manufacturers. This means that customers can now build their substation with devices from different manufacturers, which was previously only possible for the protection equipment.

Reverse Interlocking Using the GOOSE of IEC 61850

■ 1. The principle of reverse interlocking

Reverse interlocking provides a low-cost way of implementing busbar protection in conjunction with time-overcurrent protection devices 7SJ62 (Version 4.7 and higher) and 7SJ64. These devices have the performance required to execute time-critical protection applications using GOOSE. The busbar is powered through a transformer feeder and the other feeders (Fdr.1 – Fdr.3) go to the loads (see Fig. 8). If very short tripping times of under 15 ms are required, a 7SS60 or 7SS52 busbar protection system must be used.

In IEC 61850, a time-overcurrent protection stage (DMT/IDMT) is described by the logical node "Protection Time Overcurrent" (PTOC). Pick-up of the stage is termed "Start" (str); tripping is termed "Operate" (Op). There is a parameterizable low-set or high-set current stage ($I>$ or $I>>$). If this is exceeded by the short-circuit current, the stage is picked up immediately ($I>$ picked up / PTOC.str). After a parameterizable time delay T has elapsed, a trip command for the stage is issued ($I>$ Trip / PTOC.Op).

On pick-up ($I>$ picked up / PTOC.str) of the time-overcurrent protection stage $I>$ in feeders 1 – 3 (Fdr.1 – Fdr.3), the $I>>$ stage of the incoming feeder is blocked via a binary input. The binary input is routed such that this blocking is active without a voltage. The $I>>$ stage of the incoming feeder is set with the delay time T (70 – 100 ms) so that reliable blocking is ensured by a pick-up (str) in the feeders before the time delay of this stage elapses in the incoming feeder. During normal operation, a voltage is applied to the binary input via a loop line through the closed contacts. This means that the high-set $I>>$ stage is not blocked and trips after the delay time on pick-up of the $I>>$ stage.

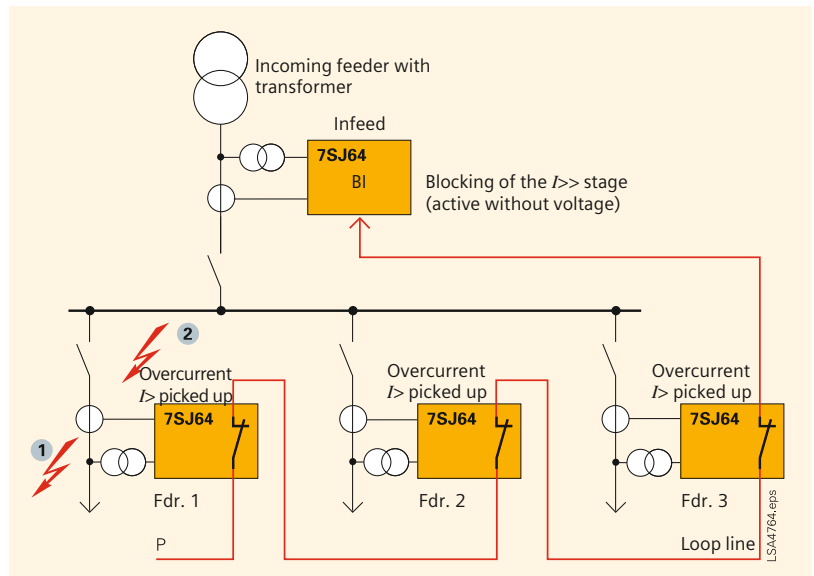

Fig. 8 Simple busbar protection using reverse interlocking

■ 2. Intended response of the interlocking to a short circuit

2.1 External short circuit on a feeder

An external short circuit at position 1 (see Fig. 8) results in pick-up of the $I>$ stage of the unit on feeder 1. This pick-up is routed to a normally-closed contact and blocks the $I>>$ stage of the incoming feeder via the binary input (BI) because the binary input is de-energized when the contact opens. The short circuit is cleared by the time-overcurrent protection device of the short-circuited feeder when its delay time has elapsed.

2.2 Short circuit on the busbar

The $I>>$ stage of the incoming feeder is set to reliably pick up value in response to a busbar short-circuit. A busbar short-circuit at position 2 does not result in pick-up by the $I>$ stages of the devices in feeders 1 to 3. After the set delay time T has elapsed, a trip command is issued and the short circuit is cleared.

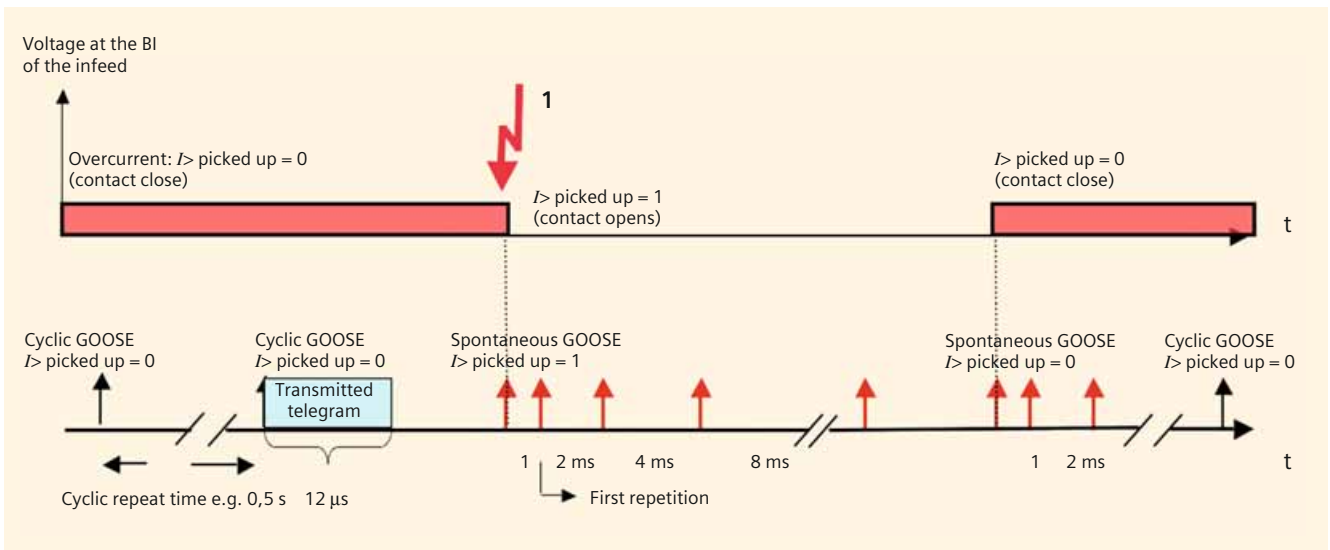

Fig. 9 How binary states are transmitted with GOOSE telegrams

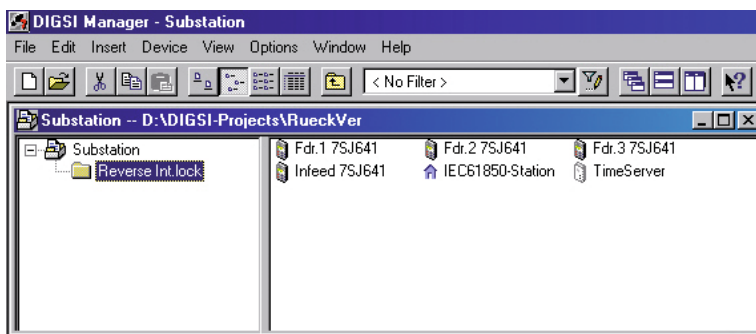

Fig. 10 Station configuration in DIGSI

■ 3. Principle of GOOSE telegram transmission (GOOSE messages) of IEC 61850

If a signal, e.g. the pick-up "Overcurrent $I/>$ picked up", is configured in a GOOSE message, the unit sends this message cyclically every 0.5 seconds as a telegram over the Ethernet network via Ethernet module EN100 at 100 MBit/s. Such a telegram is just a few microseconds long. The GOOSE message is transmitted with high priority in the network. The cyclic repeat time can be set in the system configurator and should be set with "high priority" in protection applications. The content of this telegram communicates the state of pick-up (not picked up or picked up) to the subscribers of the GOOSE message. The cyclic transmission enables each of the subscribers to detect a failure using a logic block when a transmitter has failed or a communications channel has been interrupted. This provides constant monitoring of the transmission line because the subscriber expects to receive a telegram at several-second intervals. This is equivalent to pilot-wire monitoring in conventional wiring. On a pick-up, i.e. a signal chan-

ge, a GOOSE telegram is transmitted spontaneously. This telegram is repeated after 1 ms, 2 ms, 4 ms etc. before returning to cyclic operation. The repeat time after a spontaneous change is also configured in the system configurator. If the pick-up drops off again within this time, the spontaneous transmission is repeated. Fig. 9 shows the method as applied to the pick-up signal. Each unit in the feeder transmits its GOOSE telegram to the unit in the incoming feeder.

■ 4. Parameterization with DIGSI and system configurator

4.1 Station configuration in DIGSI

First, a station is configured with the devices in DIGSI (see Fig. 10). In addition to the devices of the feeders and the incoming feeder, an IEC 61850 station is also required, which will later contain the system configuration. Using the time server, which may be integrated into the PAS master unit, the time in the devices is synchronized via the SNTP – protocol via Ethernet. The devices only require the network address (IP address) of the time server.

4.2 Settings in the devices of the feeders

Only settings that are necessary for this application are discussed here. In practice, there will be further functions and routings to set. The IED name must be entered under the "Object properties" -> "Communication parameters". It is required in the IEC 61850 configuration to identify the device (see Fig. 11). The network parameters are later set in the system configurator.

The device must then be opened and saved again to generate an IEC 61850 configuration file (ICD file).

Under "Time Synchronization", "Ethernet NTP" is selected (Fig. 12). Settings for the time zone and daylight-saving/standard time switchover can be set for a specific region. With this setting, the device queries the SNTP timer about once a minute. The IP address of the time server is set in a standardized way for all devices in the system configurator and does not have to be configured separately in each device.

In the network topology (see Section 5), the devices works with an integrated switch in the optical ring. Under "Communication" -> "Ethernet on device", "Switch" mode must be chosen for the optical module (Fig. 13). This setting must be made in the optical ring for each device. This dialog box also allows you to check the set IP address later.

In the routing matrix, the signals to be transmitted as the destination via the system interface S are configured. Because the $I \rightarrow$ picked up indication is defined as a mandatory message in the IEC 61850 standard, it is already routed to S and cannot be unrouted by the user. With a right-mouse click on the message, it is possible to view the IEC 61850 message text under "IEC 61850" (PROT/PTOC6/Str). This information is also seen as plain text in the protocol and will later be required in the system configurator (see Fig. 14 on the following page). After that, the unit is saved and DIGSI automatically creates all the data of the device that is necessary for IEC 61850 configuration.

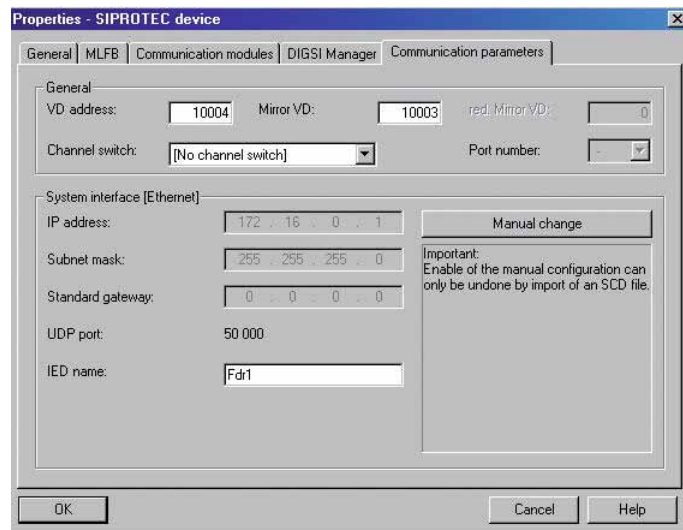

Fig. 11 Setting of the communication parameters

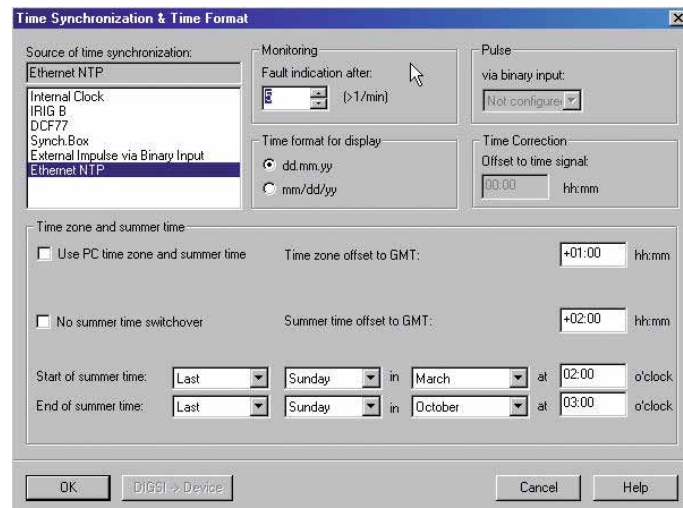

Fig. 12 Time setting dialog box in DIGSI

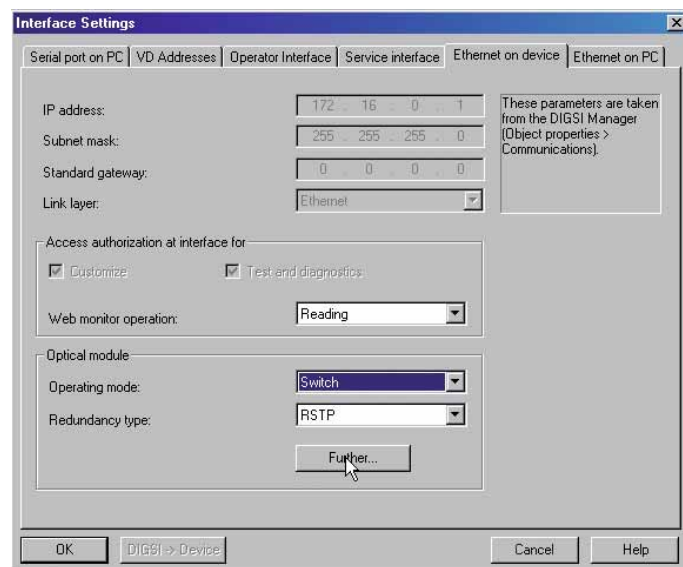

Fig. 13 Settings for the integrated switch

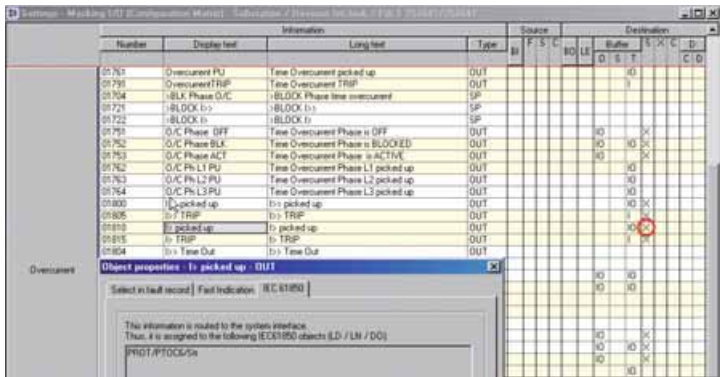
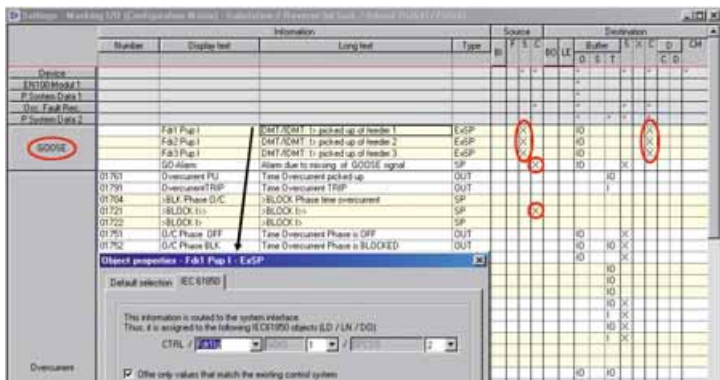

Fig. 14 Routing of the pick-up message on system interface IEC 61850 message text in "Object properties" window

LSP2859en.eps

long text are edited for the message (DIGSI text). The message is routed to the system interface as a source and must be provided with an IEC 61850 message text in a property window (see Fig. 15). The structure of the text is largely defined by the standard. This text is required in the system configurator. The messages are routed into the logic editor "CFC" as destination and further processed there. Blocking of the $I \gg$ stage " \gg Block $I \gg$ " is routed to the CFC as the source because the blocking is mapped there by logic blocks. Moreover, a further message is created in the GOOSE group that generates an alarm if there is a disturbance in the GOOSE link (GO-alarm). This information can, for example, be routed to an LED, a contact, or the system interface as the destination and used as an alarm in the substation control unit.



Configured IEC 61850 message text

LSP2860en.eps

4.4 Settings in the CFC in the device of the incoming feeder

With a little logic, the blocking and alarming is performed in the CFC. Time-critical protection applications must be processed in the fast CFC charts. The new chart is named GOOSE.

Fig. 15 Settings in the device of the incoming feeder in the routing matrix

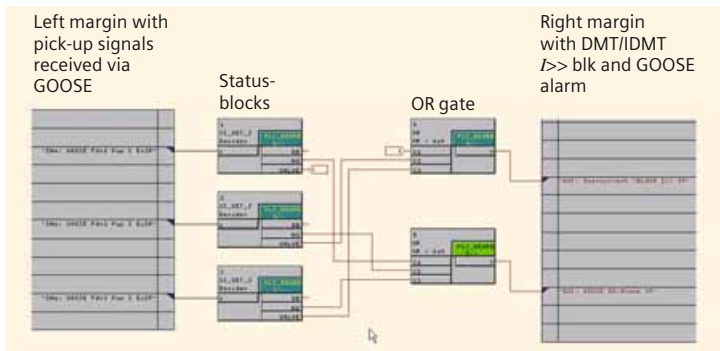

LSP2861en.eps

Blocks of category "SI_Get_Status (Decoder)" are inserted and each is connected to the pick-up signals of the right-hand margin (sources) (see Fig. 16). Such a block has a "Value" output that indicates the ON/OFF state of the message at the input. The "NV" output stands for "not valid". If a GOOSE signal is no longer received, this output is set. The pick-up signals are connected to an "OR block" whose output goes to the blocking of the $I \gg$ stage on the right-hand margin. The NV outputs are connected with the GOOSE alarm via an OR block. Depending on the operator philosophy, this signal can also be used for other actions, e.g. blocking the stage.

Fig. 16 Formation of the blocking $I \gg$ stage and the GOOSE alarm in the CFC

4.3 Settings in the device in the incoming feeder

Here, more extensive settings must be made. "Ethernet NTP" is selected as the time synchronization source and the integrated switch is set.

A new information group is inserted in the routing matrix and named "GOOSE". Here, new messages of the object type "External single point" from the information catalog are required. For each transmitted pick-up indication of a feeder, a corresponding message is required with which the start message is further processed. A meaningful short text and

4.5 Settings in the system configurator (Fig. 17)

First of all, all IEC 61850 devices of the station are added to the system configurator. This also adds the ICD files of the devices. This is done in the "Station Manager" with a right-mouse click on the IEC 61850 station under "Object properties" -> "Communicator". Then the system configurator is opened.

There, the first step is to set the IP addresses of the devices. DIGSI suggests network addresses, which are normally accepted. Note that network addresses of other devices, for example, the time server, the PAS, and the switches must be set with the configuration software of these devices. Only the IP addresses of SIPROTEC units are configured with DIGSI. Moreover, the system configurator does not show all devices. To avoid network conflicts due to duplicate IP addresses, it is advisable to draw up a list of all network devices.

The next step is switchover to the connection view. The system configurator offers a default GOOSE application that is renamed in the right-hand "Properties" window (Reverse Interlocking) and is set to high priority. This means that the GOOSE messages are repeated cyclically and spontaneously with high frequency: every 0.5 s cyclically, starting with 1 ms repetition on a spontaneous change to a message.

The devices are listed with their signals on the left-hand side below. For each device, the protection pick-up must now be inserted as the source signal in the connection view. It is helpful if the familiar SIPROTEC texts are displayed along with the IEC 61850 standard text (e.g. Fdr1.PROT.PTOC6.str.general). On the right, the destination signals are available that have been configured as "External single point indications" in the device of the incoming feeder. In the connection view, a "Source" is now connected to the "Target". This is equivalent to conventional wiring of a contact to a binary input. A source signal can also be connected to multiple destinations, although this is not required in this case.

When configuration has been completed, it is saved and the system configurator is closed. A configuration file of the station (SCD file) is then generated automatically, which is in conformance with the IEC 61850 standard part 6.

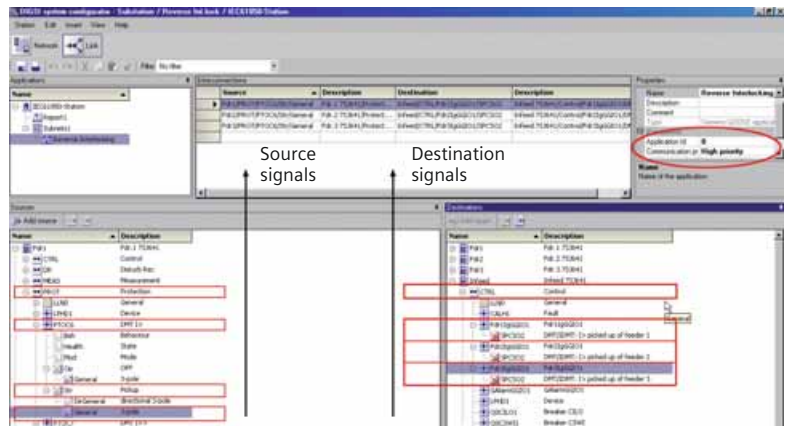

Fig. 17 Configuration of the signal connections in the system configurator

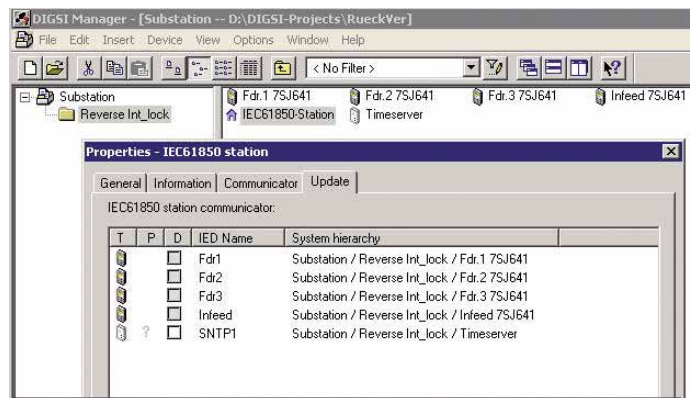

Fig. 18 Updating of the devices with the IEC 61850 configuration

4.6 Loading of the configuration data into the devices

Under "Properties" (right mouse click on IEC 61850 station) and "Update" the parameter sets of the devices are now updated with the IEC 61850 relevant data. The devices only have to be initialized once via the front serial interface. Then they are assigned with network addresses and IEC 61850 configuration data. Further updates can be performed via the Ethernet interface (Fig. 18).

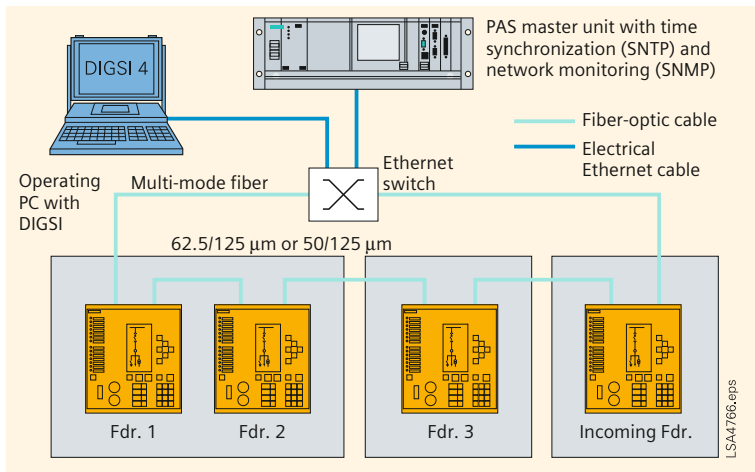

Fig. 19 Structure of the Ethernet network as an optical ring

5. Network topology

The network is implemented as an optical ring that is terminated with a switch (see Fig. 19). At this point, a PAS master unit is connected. This unit is not involved in the GOOSE application but may, for example, read out messages and fault recordings from the devices and can pass on the GOOSE alarm. It can additionally monitor the topology of the network, which is implemented using a special monitoring protocol SNMP. It also performs time synchronization in the network with 1 ms accuracy via the Simple Network Management Protocol (SNTP).

In the devices, an optical Ethernet module with an integrated switch is used. This achieves a maximum of electromagnetic immunity and fault-free data transmission. With conventional wiring, the signal wires can be prone to high interference voltages. Except for the SIPROTEC devices, few other network components are required, which reduces the configuration effort and increases the reliability of the system. The failure of one device is tolerated in the optical ring because the network restructures itself into two chains in a matter of milliseconds and the devices can continue to intercommunicate. The data traffic is controlled by special filters on the optical module to ensure that GOOSE telegrams are only listened to in the devices that expect information from a GOOSE telegram. This reduces the processor load on the Ethernet module, which is not constantly troubled with telegrams with irrelevant content, as GOOSE telegrams are always sent to all devices. GOOSE telegrams are also prioritized over regular data traffic, which is a special feature of the IEC 61850 GOOSE. A GOOSE message passes through the integrated switch of a device in 4 μ s, so that it runs through the ring almost without delay.

6. Summary

Using the peer-to-peer communication of IEC 61850, parallel wiring between bay control units can be replaced by GOOSE. This can also be used for time-critical protection applications. This requires the use of devices with high computing power, such as 7SJ64, 7SJ62 as from Version 4.7, 7SA52/6, 7SD52/6, 7UM62, and 6MD66. In place of hardwiring, the DIGSI software is now used for configuration according to the methods standardized in IEC 61850.

Optical links permit reliable operation. Due to the ring topology of the network and extensive monitoring functions, component failure can be detected in a matter of seconds. This results in high availability because operation can continue even if one component fails. These monitoring mechanisms are comparable with the constant pilot supervision of wire connections, which is usually only implemented for tripping circuits because of the extra costs incurred for external components. Using the GOOSE mechanism of continual repetition of telegrams and intelligent monitoring modules in the device, monitoring is implemented in the software, as is already the state of the art in digital communication links, for example in differential protection.

Nevertheless, the method does require thorough commissioning that verifies correct functioning and checks the time response. This is supported by the internal logging of the devices and test tools. Test equipment and software tools are now available that trace the GOOSE messages on the bus and make a record with millisecond precision, in the same way as for binary signals that are generated via contacts.

Beneficial Engineering of IEC 61850 Substation Automation Systems

■ 1. Introduction

Engineering expenses dominate both the investment costs of an SAS (Substation Automation System). Consequently, the main way to reduce these costs is to optimize the engineering process.

The process of engineering an SAS involves several activities: system design and specification, device and system configuration, device parameterization, documentation, testing and diagnostics, and commissioning. Each activity includes several system levels, ranging from process interface, protection, and communication settings up to SCADA functionalities.

The current practice in engineering an SAS is to use vendor-specific tools, each of which is designed for a particular engineering activity and a particular system level. As a consequence, the engineer ends up using a chain of tools, especially in multi-vendor applications, and expending a lot of effort on data entry (often entering the same data multiple times into various tools), data exchange, and manual data conversion between tools. In addition, these tools rarely support the reuse of engineering data from existing installations in new or retrofitted projects.

The communication standard IEC 61850 offers great hope for simplifying this process. With its object-oriented data model and formal description language, it promotes reusability, data interoperability, and seamless engineering.

In the pages that follow, the challenges involved in the process of engineering an SAS are described. Then, the requirements for an efficient and comprehensive work flow both in the project process and at the system level are defined. Then, it is shown how IEC 61850's intelligent methodologies can overcome these limitations and improve engineering efficiency.

■ 2. Engineering process

Engineering an SAS to the point of system completion and operation involves several project phases. Aside from commercial and project management matters, all of the project's technical concerns fall in the category of engineering. In the substation-automation domain, the term engineering includes all technical activities necessary for building and running an SAS over its complete life cycle – including modifications and extensions. These engineering activities include: system specification, device and system configuration, device parameterization, documentation, testing, diagnostics, and commissioning.

2.1 Engineering roles and active parties

During the engineering of a substation automation project, several parties are involved. Typically, the active parties include the utility, the consultant, the service provider, and the vendor. Depending on the project conditions, these parties can play different roles regarding engineering activities. With respect to the engineering phase of a project (commercial matters are already clarified), the basic roles include system owner, system integrator, and operator. The role of the system integrator includes all activities from system design and planning through the commissioning stage. Thus it is not unusual for the role of system integrator in a project to be split among multiple parties.

In most projects, the utility specifies the SAS and buys a turnkey system. In this case, the utility is usually the system owner and operator, while the vendor or service provider is the system integrator.

In addition, various other arrangements are possible, with the active parties playing different roles, see bibliography on page 19, reference [1].

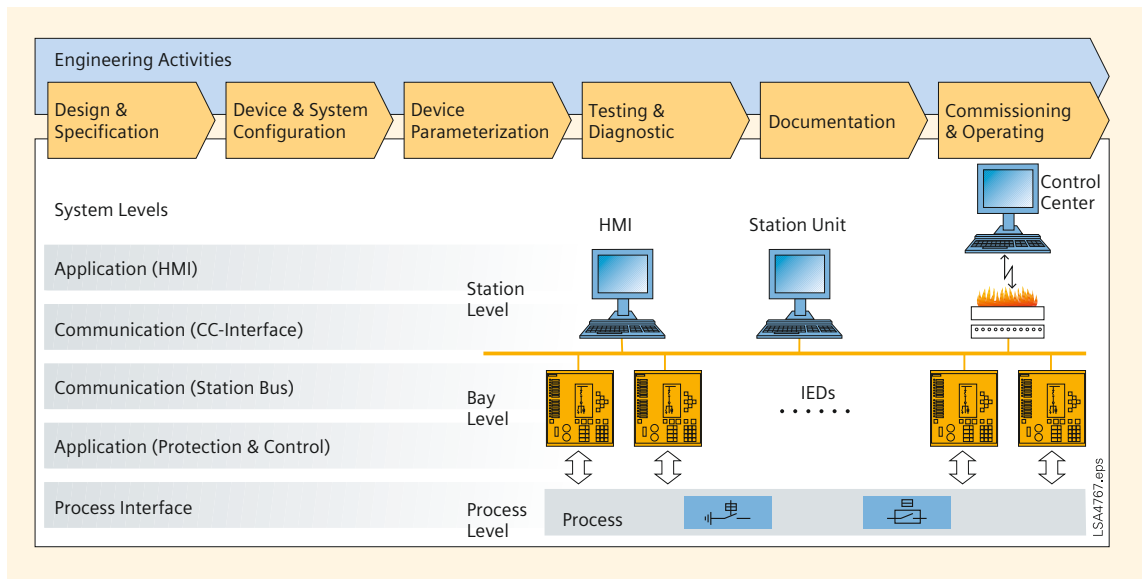

Fig. 20 Engineering activities and system levels

2.2 Engineering activities

Fig. 20 shows the engineering activities and system levels involved in erecting or retrofitting a typical SAS. The structure of the SAS consists of bay controllers and protection relays, which are connected to the primary equipment via a process interface. These IEDs at the bay level communicate with each other, and with IEDs at the station level, via a communication infrastructure. Communication to a remote control center is implemented by a WAN connection.

Due to these different system levels – ranging from process interface up to SCADA functionalities – engineering is carried out both in the horizontal direction (activities) and in the vertical direction (system levels) in order to complete a system.

A short description of the engineering activities is given below.

a) Design and specification

This phase involves planning and specifying the layout, functions, and applications of an SAS. These tasks can be carried out by the utility, the service provider, the consultant or the vendor.

Generally, the requirements of the primary system determine the design of the secondary system. The functions and applications of the primary system regarding protection, operation, and monitoring are compiled and mapped to the secondary system according to each application. Usually, the customer's philosophy and requirements influence the specifications of the functions and applications in areas such as the protection scheme, the con-

trol hierarchy, interlocking, and the HMI design (including how all these functions are distributed to IEDs). The design process involves defining details such as process parameters (for example, current and voltage scaling), system parameters (for example, data exchanged for interlocking purposes), and setting values (for example, pick-up values for the overcurrent protection). The result is an application-specific data model that is represented by specifications typically documented in the form of written requirement specifications, including flow-charts and signal lists.

Based on these specifications, a system configuration and appropriate IEDs meeting the functional requirements are selected.

b) Device and system configuration

This phase involves configuring the selected SAS solution. A system integrator usually performs this task.

Configuration typically begins with devices. Starting from the requirement specifications, the desired functions and applications are translated into a device-specific data model and operation code. These include protection settings, interlocking terms, CFC-Logic, HMI mimics and diagrams. Device-specific tools are used for configuring these items.

The communication infrastructure can be seen as the backbone of an SAS. Merging the devices to a system by communication is the scope of system configuration. In system configuration, the communication parameters are set in order to determine what data is

exchanged – and how it is exchanged – between devices, station unit, HMI, and remote control centers.

c) *Device parameterization*

In this phase, the system integrator deploys the device-specific data models, settings, and operation code to the appropriate devices. Naturally, device-specific tools are used for downloading the data to devices.

d) *Testing and diagnostics*

Testing and diagnostics are crucial for confirming proper operation of an SAS – or for trouble-shooting, in case of malfunction. The testing and diagnostic tools are predominantly vendor-specific, often functionally integrated within device configuration tools. Extensive testing takes place during FAT, commissioning, and SAT, usually with the support of monitoring and diagnostic tools.

e) *Documentation*

The documentation is carried out by a system integrator and includes:

- Electric circuit diagrams of the complete SAS
- Signal lists
- Communication address lists
- Parameter settings (process, protection, and communication)
- Data lists for bit tests
- Operational and technical manuals
- Acceptance reports
- Commissioning reports

f) *Commissioning and operation*

Commissioning begins after the system is installed and passes its acceptance tests. The system integrator usually performs this task, together with the owner or the operator or both. During the operation phase, periodic or condition-based maintenance activities take place. In addition, modifications or even system extensions may require re-engineering.

2.3 *Limitations and issues*

In practice, the engineering process described above is rarely seamless and straightforward – mainly because it requires vendor-specific tools designed for a particular engineering activity and system level, and the use of proprietary data models. Projects with a homogenous system platform (all devices from the same vendor) involve relatively minor issues, as the tools are usually coordinated to cover

multiple system levels and activities. But in multi-vendor applications – typically in high voltage (> 110 kV), exchange, or extension projects – tool import and export qualities play a major role.

The use of multiple tools in a project has the following consequences:

- The engineer has to pass the process through a chain of tools, often with iteration loops.
- The same data must be entered multiple times for different devices and system levels.
- System integrators and operators have to handle a multitude of devices and tools (varying in type, manufacturer, technology, and modeling), each of which requires appropriate training and know-how.

The data models of most tools are strongly signal-oriented. As a result, mapping data to HMI applications requires extensive conversions to technology-oriented objects (e.g. circuit breakers, disconnectors, transformers, and so on).

In addition, it is common in project activities that most artifacts (requirement specifications, documents, signal lists, data models, and so on) are neither standardized nor uniform. These items are strongly influenced by customers' and vendors' work practices, tools, and philosophies. So, the following limitations and consequences occur:

- Extensive data conversions are required among tools
- Reuse of engineering data is difficult

■ 3. Requirements

To avoid the above-mentioned limitations and issues, an efficient engineering process needs to meet the following requirements regarding data models and tools:

- Standardized and technology-oriented data model
- Unified interchange format for data-model representation
- Standard import and export interfaces for all tools
- Template support for easy reuse of engineering data in all types of cases, from simple system extensions up to delta engineering of complete systems
- An interface that hides complexity from users as a default, with expert mode available on demand
- A single-tool model (covering a wide product range) in order to reduce the number of tools used in a project
- Integrated communication configuration capabilities to further reduce the number of tools used per project
- Vendor-independent testing and diagnostic tools
- Well defined interfaces between user roles

■ 4. Benefits of IEC 61850 engineering

4.1 Key features of the IEC 61850 standard

The short abstract that follows provides a basic understanding of IEC 61850 – its principles, concepts, and methodologies.

Unlike other applied communication standards, such as IEC 60870-5-101 /-103 /-104, the IEC 61850 standard goes beyond just communications.

Key features are:

- An object-oriented and application-specific data model focused on substation automation, see bibliography on page 19, ref. [2-4]. This model includes object types representing nearly all existing equipment and functions in a substation – circuit-breakers, protection functions, current and voltage transformers, waveform recordings, and many more.
- Communication services providing multiple methods for information exchange. These services cover reporting and logging of events, control of switches and functions, polling of data-model information, real-time peer-to-peer communication (GOOSE), sampled value exchange, and file transfer for disturbance recordings, see bibliography on page 19, ref. [5, 6].

- Decoupling of data model and communication services from specific communication technologies. This technology independence guarantees long-term stability for the data model and opens up the possibility of switching over to successor communication technologies, see bibliography on page 19, ref. [7].
- A common formal description code, which allows a standardized representation of a system's data model and its bindings to communication services, see bibliography on page 19, ref. [8]. This code, called SCL (Substation Configuration Description Language), covers all communication aspects according to IEC 61850. Based on XML, this code is an ideal electronic interchange format for configuration data. It provides for the following four types of SCL files:
 - SSD (Substation Specification Description) files: these include primary equipment and topology information and its bindings to basic application functions. The use of SSD files is optional.
 - ICD (IED Capability Description) files: these include information about the functional capabilities of an IED.
 - SCD (Substation Configuration Description): these include the configured data models and communication settings of all IEDs participating in an SAS
 - CID (Configured IED Description) is an IED-specific subset of the SCD, which includes all relevant information for an IED. Its use is optional.
- A description of requirements of the system and project management process and of special tools for engineering, see bibliography on page 19, ref. [9]

With SCL, the IEC 61850 standard introduces a powerful and unique feature into the substation-automation domain. SCL allows a uniform and vendor-neutral representation of a system's communication configuration to be used over the complete system life-cycle.

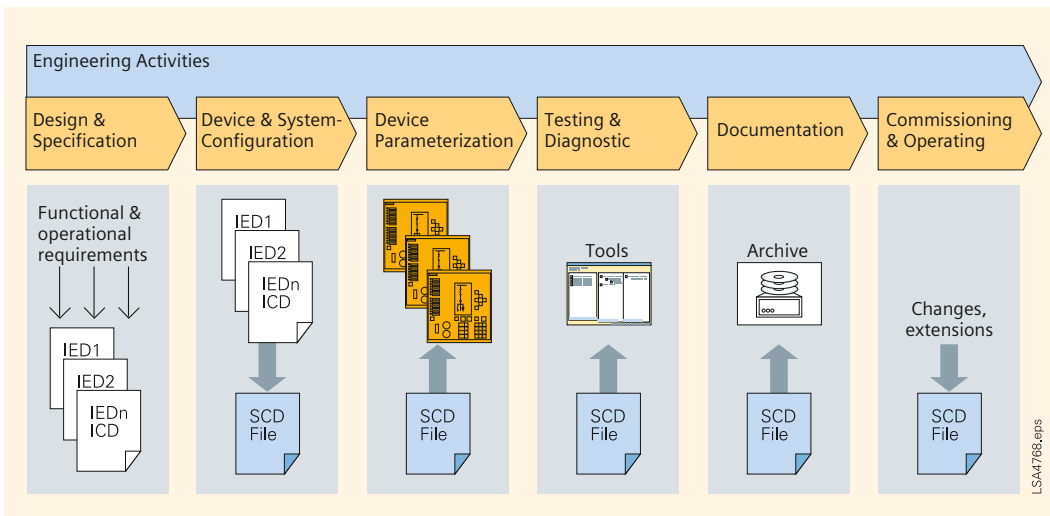

Fig. 21 The principles of SCL-centered engineering.

ICDs = IED Capability Description files,
SCDs = Substation Configuration Description files.

4.2 The SCL-centered engineering process

Today vendors offer powerful tools which are capable of handling SCL and meeting the requirements in terms of beneficial engineering. These tools make the SCL-centered engineering process a reality. The sections that follow describe the SCL-centered engineering methodology and present its benefits. Fig. 21 illustrates how the SCL files are passed through engineering activities.

a) Design and specification

Specification data that is not relevant for communication is still in the form of drawings, tables, and CFC charts. The system specification can be carried out with a dedicated system specification tool in order to create an SSD file, but this method first may provide real benefits for substation to control center communication in the future.

However, all specification data directly applicable to communication can be covered by means of IEC 61850. Therefore it is important to select suitable devices that provide specified functionality and map the application-specific data to the IEC 61850 data model. The result of such device specification is the collection of ICD files in accordance with the IEDs that are used.

Benefits:

- Selection of conformance-certified IEDs. With its standardized conformance testing, the standard allows selection of devices with conformance certificates. This ensures a high degree of interoperability and performance.
- Automatic creation of IED-specific IEC 61850 data models in the form of ICD files. In the case of device specification,

such tools offer the benefit of automatically creating the 61850 data model. For example, in the case of a tool for control and protection devices, when the control of a switch is required, the tool automatically maps it to the IEC 61850 domain by creating appropriate instances of data objects (logical nodes XSWI, CSWI, CILO).

b) Device and system configuration

The detailed configuration of application functions – such as protection, control, interlocking, and so on – is within the scope of device configuration. With its uniform naming convention, the IEC 61850 data model allows the use of seamless object and signal names in tools. Object-oriented filtering offers distinct advantages in configuration, especially during configuration of the HMI and the control center.

The system configuration includes all use cases for the configuration of communication applications. This configuration can be performed by the system configurator tool, which is advantageously implemented in the device configuration tool. The system configurator tool imports all ICD files and sets basic communication settings (e.g. IP addresses), report configurations, and GOOSE configurations. In this manner, it creates the system's SCD file.

Benefits:

- Seamless naming of data objects. Standard naming conventions simplify data mapping to HMI and control-center applications.
- Simple handling of communication. Hiding complexity from users simplifies configura-

tion and makes it easier to focus on the application itself.

- Built-in quality management. The built-in support of revision tags in SCL allows more effective detection of changes in configuration files. In addition, the provided tools validate the IED model against the standard and check its consistency.

c) *Device parameterization*

The SCD file is deployed to all participating IEDs. After importing the SCD file, the device tools extract the relevant data subset and download the configuration data to the IED.

Benefit:

- One common configuration file for all IEDs. No additional device-specific communication configuration is needed.

d) *Testing and diagnostics*

Based on Ethernet technology and on a standardized protocol stack, the IEC 61850 standard offers several advantages for testing and diagnostics.

Benefits:

- Simulation and testing of IEDs. With special testing tools, it is possible to test communication behavior by simulating heavy network traffic or special telegrams. These tools – and also the testing equipment for protection functions – can import SCD files for simpler handling.
- Vendor-neutral testing and diagnostic tools allow staff training to focus on fewer tools. Due to the standardized protocol stack of IEC 61850-8-1, object browsers of IED vendors or test equipment manufacturers can be used for all IEC 61850-compliant IEDs – and for network-traffic analysis tools that are well established outside the substation-automation domain.

e) *Documentation*

The SCD file represents the electronic documentation of the communication configuration of an SAS. This file offers the following advantages for documentation purposes:

Benefits:

- One common representation of the communication configuration of a complete system.
- Automatic creation of data lists for communication tests.

f) *Commissioning and operation*

The standardized and technology-oriented data model of the IEC 61850 standard, when combined with a tool that supports object-oriented templates, opens various benefits for current and future systems. In addition, the comprehensive IED data models provide valuable information for the utility.

Benefits:

- Simple changes and extensions. When an IED is modified, any changes in a template are propagated to all instances of this template. Templates can also allow creation of a new bay, including all necessary IEDs – a much more efficient method than using copy and paste.
- Access to maintenance data. During operation, it is easy to read information needed for asset management, including name plates, switching operation counters, switching currents, and so on.

4.3 *Delta engineering*

Delta engineering is the most efficient way to engineer a new system. It involves taking an existing configuration and applying changes and extensions in order to meet the new requirement specification. This method is not new, but with IEC 61850's benefits – especially its data model – a higher level of reusability is attainable.

■ 5. *Summary*

Optimizing the engineering process offers great potential for reducing investment and installation costs of substation automation systems. The IEC 61850 standard provides several features that allow streamlining of all activities from specification up to the operation phase.

A promising lever for increasing efficiency of engineering in substation automation is the vertical expansion of the IEC 61850 standard. By closing the gaps between substations and control centers and between process and bay level, the IEC 61850 standard's seamless communication will overcome the last of the communication discontinuities.

Bibliography

- [1] K.-H. Schwarz "Impact of IEC 61850 on system engineering, tools, peopleware, and the role of the system integrator", Proceedings of Distributech, San Diego, USA, Feb. 2007.
- [2] IEC 61850-7-1, "Communication networks and systems in substations – Part 7-1: Basic communication structure for substation and feeder equipment – Principles and models", Ed. 1, Jul. 2003.
- [3] IEC 61850-7-3, "Communication networks and systems in substations – Part 7-3: Basic communication structure for substation and feeder equipment – Common data classes", Ed. 1, May 2003.
- [4] IEC 61850-7-4, "Communication networks and systems in substations – Part 7-4: Basic communication structure for substation and feeder equipment – Compatible logical node classes and data classes", Ed. 1, May 2003.
- [5] IEC 61850-8-1, "Communication networks and systems in substations – Part 8-1: Communication Service Mapping (SCSM) – Mappings to MMS (ISO 9506-1 and ISO 9506-2) and to ISO/IEC 8802-3", Ed. 1, May 2004.
- [6] IEC 61850-9-2, "Communication networks and systems in substations – Part 9-2: Specific Communication Service Mapping (SCSM) – Sampled values over ISO/IEC 8802-3", Ed. 1, Apr. 2004.
- [7] IEC 61850-7-2, "Communication networks and systems in substations – Part 7-2: Basic communication structure for substation and feeder equipment – Abstract communication service interface (ACSi)", Ed. 1, May 2003.
- [8] IEC 61850-6, "Communication networks and systems in substations – Part 6: Configuration description language for communication in electrical substations related to IEDs", Ed. 1, March 2004.
- [9] IEC 61850-4, "Communication networks and systems in substations – Part 4: System and project management", Ed. 1, Jan. 2002.

Innovative Solutions for Substation Control with IEC 61850

■ 1. Introduction

Since IEC 61850 was published as an international standard for communication in substations, the standard has found broad acceptance on the markets. In the first substations to use it, the primary aim was successful implementation of existing concepts and solutions using the new technology. This positive experience from the initial projects secured the trust of the substation operators. However, these substations did not yet make use of the potential of IEC 61850.

With the rapidly growing number of implemented substations, confidence grew in the equipment and the first applications arose that made specific use of the new technology. The most frequent control application was the decentralization of switchgear interlocking using GOOSE messages.

The new communication standard contains much more comprehensive definitions than other protocols and is primarily intended to improve interoperability between devices

from different manufacturers, provide long-term investment protection and implement efficient exchange of object-oriented data models between engineering systems. In addition, IEC 61850 offers the possibility of replacing parallel wiring with Ethernet and of implementing fast information exchange between devices. This article chiefly deals with this aspect and contrasts these concepts with the conventional approach.

Two practically proven examples demonstrate how modern solutions for digital substation automation incorporating new functions from IEC 61850 increase the benefit for users.

The application examples are

2. *Distributed synchro-check* (page 22)
3. *Mash station automatic switching* (page 24)

■ 2. Distributed synchro-check

2.1 The application

The synchro-check function checks before closure of a circuit-breaker whether the electrical parameters of the two subnetworks are within the defined limits. This check is necessary to limit transient phenomena on connection. For this purpose, the voltage of the feeder to be switched is compared with the busbar voltage for magnitude and phase angle, and frequency values.

For safety and cost reasons, a voltage transformer is rarely mounted directly on a busbar in modern systems. To determine the voltage on the busbar, a reference bay is selected by application software. The bay control unit (BCU) in this reference feeder switches the voltage to a ring line via a relay. This ring line distributes the voltage to all bays and the BCU in the feeder to be switched picks off the voltage from the ring line. Now, all necessary information is available and the BCU autonomously checks whether the synchro-check conditions are fulfilled. If the voltage amplitude, angle, and frequency differences are within the defined limit values, release is performed by the synchro-check function and the circuit-breaker closes.

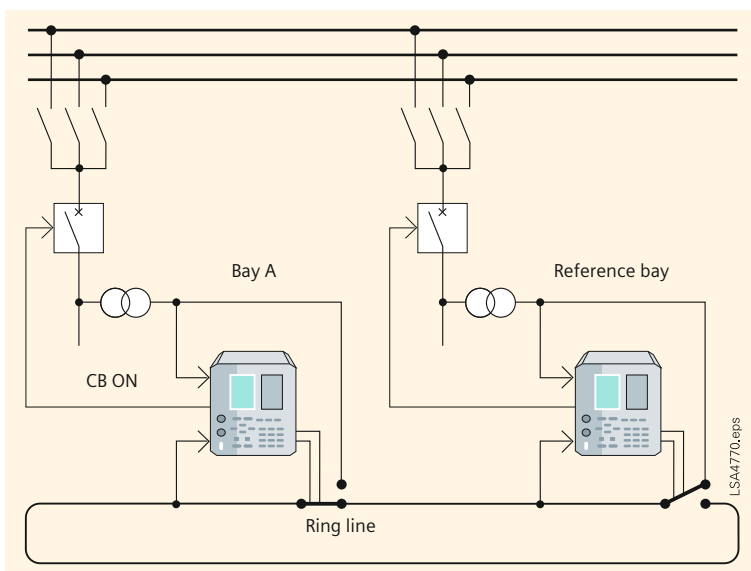

Fig. 22 Configuration for the distributed synchro-check

2.2 Conventional concept

Implementation of the distributed synchro-check function with digital control technology has been state of the art for many years. In most substations with this functionality, the logic for determining the reference bay is implemented centrally in the station control unit. This means the control at station level issues a command to close the circuit-breaker of a bay A. This command is received in the station control unit and the reference bay is selected in centralized logic that takes account of the relevant position indications and information items. Then the station control unit sends a command to the selected BCU in the reference bay to close the ring line relay. The BCU of bay A can then run the synchro-check.

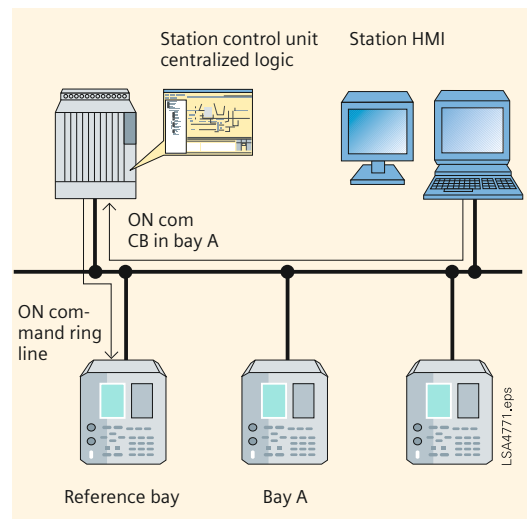

Fig. 23 Command sequence in the conventional concept

2.3 Concept using peer-to-peer communication

Since the introduction of IEC 61850, a new communication service has been available for efficient distribution of information between devices of the bay level. The application described here shows how the GOOSE (generic object-oriented substation event) mechanism can be used to advantage.

This represents a decisive change as compared with the conventional, centralized concept. Having received the command from the control point with switching authority, the BCU distributes the information “Reference bay search” to all other BCUs in a GOOSE telegram. The same logic to determine the reference bay runs in parallel in all BCUs. As in the conventional concept, the logic considers the position indications and additional information items in determining whether each feeder can be used as the reference bay. The non-bay-specific data that is required for selection is also exchanged among the BCUs in GOOSE messages. In typical substations, several bays are usually suitable for use as reference bays.

A single reference bay is selected by taking into account a previously defined sequence in the local logic.

The BCU that is located in a reference bay due to the topology information and is at the head of the sequence sends the “Reference bay found” message to all other BCUs in a GOOSE telegram and connects the voltage via the ring line relay.

The ensuing test of the synchro-check conditions in the BCU of bay A and release of the control command is performed in the same way as in the conventional concept.

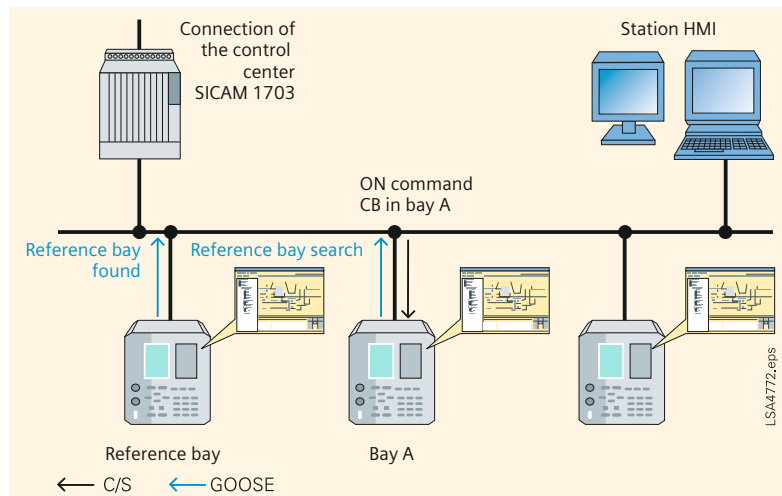

Fig. 24 Sequence when peer-to-peer communication is used

2.4 Benefit of the solution

Migrating the logic function from the BCU to the bay level improves the availability of the solution. Depending on the level of system availability required, redundant implementation of the station control unit can be dispensed with. If one BCU fails, the BCU with the next highest priority is used as the reference bay. The synchro-check function is available for switching via the remote interface, the station control, and also for switching from the local control. This ensures reliable and synchronous switching in all operating cases.

■ 3. Mesh station automatic switching

3.1 Background

A mesh station is a type of primary substation configuration that is economical in its use of circuit-breakers. Although there are many variants, the typical configurations are single switch and four switch meshes, the names inferring the number of circuit-breakers used to accomplish the layout.

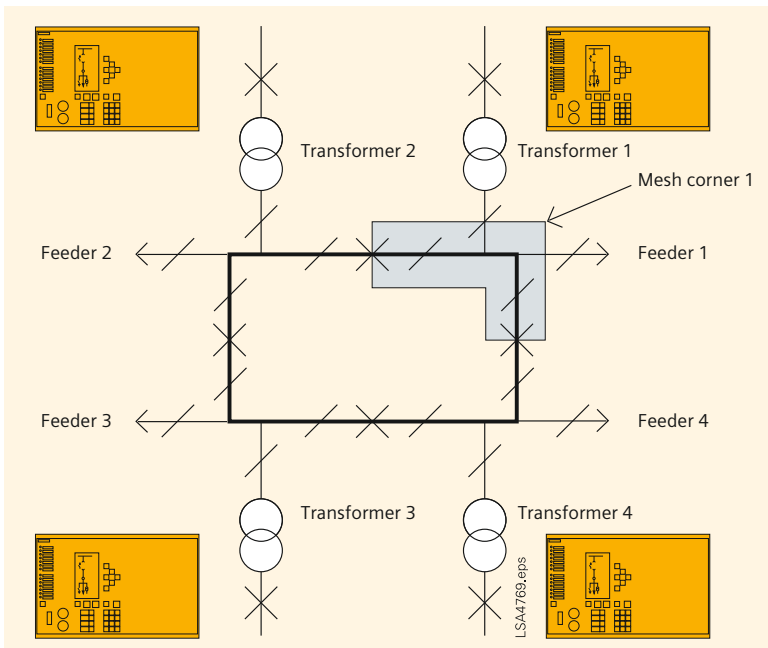

Fig. 25 Mesh station

A mesh corner is where busbars connect circuit-breakers, transformers and feeders – a four switch mesh has four mesh corners, whereas a single switch mesh has 2 corners. Feeders or transformers connect to mesh corners via motorized disconnectors to provide individual isolation and it is possible to have more than one transformer connected to the mesh corner. A mesh corner would typically have a feeder and up to two transformers connected – this means with four circuit-breakers, a station could be built with 4 feeder and 8 transformer circuits. If a circuit-breaker requires maintenance, it may be taken out of the mesh without any loss of supply.

3.2 Mesh station automatic switching

Following a trip event for the mesh to 'self heal', an automatic switching and delayed automatic reclose (DAR) system is required.

For example, for a feeder fault, all circuit-breakers connected to the feeder's mesh corner must trip, including any transformer low-voltage circuit-breakers and remote substation circuit-breakers through intertrip signalling.

The mesh station circuit-breakers have priorities and dead timers, so after the fault a mesh circuit-breaker will attempt closure which, if successful, will result in all other circuit-breakers closing in a controlled sequence. If the first circuit-breaker to automatically close trips then the feeder is deemed to have a persistent fault and the mesh DAR system opens the feeder disconnector at both ends of the circuit – after the feeder has been removed from the mesh corners, the mesh circuit-breakers commence automatic reclosure.

For transformer faults, once circuit-breakers have tripped, the transformer is automatically isolated by opening its disconnector before the mesh circuit-breakers reclose in their sequence.

3.3 The solution

A solution with one BCU per mesh corner was developed.

This gave the benefits of reduction of installation costs and using a future proof industry standard rather than a bespoke solution.

The automatic switching and delayed automatic reclosure functions were developed using a graphical logic tool which was used to diagnose the bay control units.

A test system shows a single line diagram of the substation from which switchgear positions can be manually changed, analog values controlled and protection events signaled. The visualization interfaces to PROFIBUS input/output devices which are in turn connected to the bay control units being tested. The test system responds to events, i.e. simulates disconnecter opening/closing and allows test sequences to be easily created and replayed for repeatable testing.

Using this test system, the specific functioning of the DAR function can easily be verified in the BCUs and there is no further obstacle to successful commissioning of the substation.

■ 4. Summary

The examples discussed show that IEC 61850 offers a wide range of application possibilities exceeding by far current applications. A thorough analysis will reveal the advantages of IEC applications. However, it is for the operator of the substation and its supplier to decide on the degree to which alterations of existing concepts and systems should be made.

Seamless Migration

■ 1. Migration strategies for connecting existing substations to IEC 61850

Most substation projects are not new substations but expansions or refurbishments. Use of IEC 61850 must therefore not be focused exclusively on new substations; strategies for connecting to existing technologies are also required. This article describes methods and solutions to achieve this.

■ 2. Migration into an existing environment

Because of the large investments required, substation renewal is a continuous process. The long service life of the systems also makes heterogeneous solutions within one substation unavoidable. One of the most important aspects of integrating old substation components is the system's flexibility with respect to existing interfaces.

■ 3. Integration of devices with an IEC 60870-5-103 interface

The most frequent application is the coupling of protection units with IEC 60870-5-103-compliant interfaces. A rounded portfolio must offer flexible options to meet the different requirements of the applications and configurations. Basically two variants can be selected. Either devices are coupled with a -103 interface by means of serial hubs or modems or direct coupling to a bay control unit is used. If a serial hub or modem is used, Ethernet is the communication medium for packing the telegrams according to IEC 60870-5-103 into Ethernet containers and for unpacking them again in the control system, allowing the control system to decode the familiar -103 telegrams. If local coupling via a bay control unit is used, the IEC 60870-5-103 addresses are assigned to a corresponding IEC 61850 address. In this case, Ethernet as the communication medium is not only means of transport; data is also converted.



Fig. 26 400 kV outdoor switchgear

LSP2864.eps

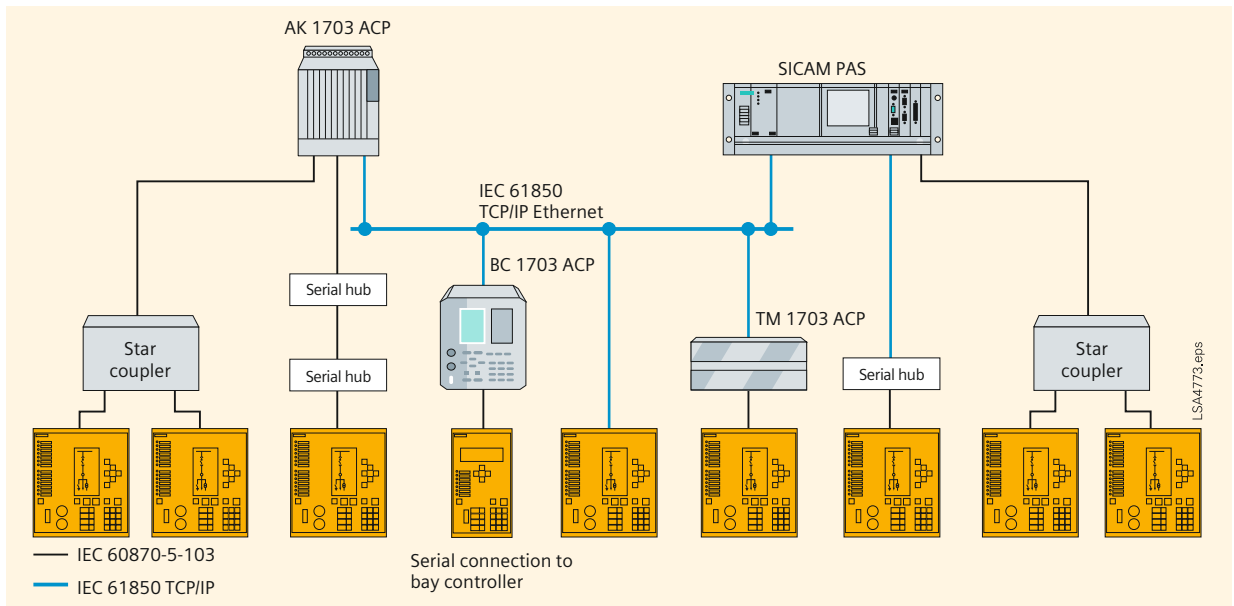

Fig. 27 Integration of IEC 60870-5-103 devices

■ 4. Coupling the control center

Another important aspect of migration is the assignment of data models and communication services of IEC 61850 to the telecontrol protocol per IEC 60870-5-101/-104 or DNP3.0 for communication with the network control center. IEC's technical committee TC 57 is currently working on a technical specification to deal with this topic. The implementation of this recommendation in products and engineering systems enables an efficient approach in each respective project and also avoids costly project-specific solutions.

Compliance with such an IEC technical specification ensures that all suppliers design the interface in the same way and that a system control center knows exactly what IEC 61850 object is behind a 101/104 information item, irrespective of which manufacturer actually installed the switchgear. Siemens AG is also providing decisive input for this standardization project and implementing it in products early on.

■ 5. Migration to company-specific precursor systems

To achieve standardization, only solutions are dealt with that are based on communication protocols that comply with the IEC standard. Every manufacturer is required to provide migration methods from the company-specific protocols previously used for substation automation or for the remote parameterization interface.

But solutions for each company's own precursor systems are not the only requirement; flexible configurations that include proprietary de-facto standards from the past must be included in the overall solution.

Only products and systems that support the different protocol environments that are necessary can permit efficient migration to IEC 61850 solutions in the retrofitting business.

■ 6. Step-by-step introduction of the IEC 61850 into a substation

The existing communication protocols are not the only important constraint that applies in practical use.

Above all, in refurbishment projects, where substations are usually equipped with the latest technology on a bay-by-bay basis, concepts are required to permit parallel, heterogeneous operation of the substation. For example, let us take a case of a substation in which the interlockings in the existing equipment were conventionally implemented by wiring while the interlockings in the new equipment make use of the GOOSE mechanism.

To prepare the interlocking logic for the final expansion stage in the re-equipped bays while also providing the functionality of interlocking across bays during the conversion phase, position indications from the hard-wired part of the substation must be taken into account in the new substation part during conversion. If a flexible coupling element

is used as a universal IEC 61850 server, this information can be connected in parallel and made available to the new part of the installation in the form of a GOOSE message. This permits step-by-step conversion of conventional substations to the latest technology and concepts while retaining a maximum of substation functionality and therefore operational reliability.

■ 7. Complete upgrade of the bay control units to the IEC 61850 protocol

Alternately, it is possible to upgrade the installed protection and control units by replacing the communication module and by upgrading the firmware to IEC 61850. This migration step provides solutions that are homogeneous, high-performance, and future-proof (Fig. 28).

■ 8. Commissioning and testing

If commissioning is to be efficient, analytical tools are indispensable. Products and systems established on the market provide extensive diagnostic and analysis functions in their engineering tools. Now, with the more advanced features of IEC 61850 and the self-description of the devices, tools are available that are unparalleled in past solutions and make analysis even more convenient for the user. With a universal browser, the control engineer is able to read out data models of any IEC 61850 device, including all its attributes, without needing to have the parametrizing tool of the manufacturer. The additional use of web technologies provides further extensive options for diagnostics and analysis.

■ 9. Benefit for the user

Protection of investments is one of the prime objectives of users when converting substations. Concepts that permit seamless conversion from old systems to new solutions make an important contribution to achieving this objective. With the concepts described here, old systems can be converted to the latest technology step by step. This ensures the best protection for investments made and the substations are prepared for further expansion.



Fig. 28 Upgrading an existing IED with IEC 61850 communication

■ 10. IEC 61850 spreads

The many substations now implemented (more than 1000 substations in 2010) are unequivocal proof that IEC 61850 provides innovative substation solutions and is technically mature and reliable. The success so far with products and systems complying with IEC 61850 and the considerable demand on national and international markets shows that previous investments in this field have paid off.

Siemens E D EA will continue its commitment to IEC 61850 both by contributing to the standardization process and by implementing the standard in devices and systems to further increase the benefit for users.

Ethernet Topologies with IEC 61850

■ 1. Introduction

Ethernet – which has been widespread in company and office networks for a long time – is becoming more and more popular in all other parts of the industry. The IEC 61850 standard specified this kind of network as the communication platform for the complete standard. Even if the bandwidth of the Ethernet increases now and over the next few years, the protocol will run in every case. Ethernet is well known all over the world and no indication of any change to this protocol is imminent. Thus Ethernet will be the basis for IEC 61850 for many years to come.

This article shall give the reader an overview of existing Ethernet technologies and common topologies with IEC 61850.

One of the most important topics in substations is the reliability of the systems and therefore also of the given communication infrastructure. Reliability is provided by several redundancy algorithms which are possible in Ethernet networks.

For a very fast transmission of so-called GOOSE messages for direct inter-bay communication the IEC 61850 standard envisaged the use of EtherType, which means that these messages run on a flat layer 2 network, without the need for layer 3 IP addresses. Other non-time-critical communications, e.g. to station controller SICAM PAS, DIGSI configuration via IP or browsing the IEC 61850 module homepage are based on the TCP/IP protocol.

Not only the network itself can have redundancies, but connection redundancies are also possible with the SICAM PAS station unit and all kinds of SIPROTEC 4 devices as well. Both IEC 61850 modules in the SIPROTEC devices, the electrical and the optical ones, have

redundant ports at the backplane. This means that each module can be connected to two different switches. If a connection is interrupted, the standby connection will be activated within some milliseconds. In the SICAM PAS station unit the same procedure is applicable with the use of a dual network card, which is also interconnected to two switches. And, of course, system redundancy is also possible.

■ 2. Services in Ethernet networks

What is the situation in existing substations today? Sometimes devices from different vendors are in use. The devices communicate with each other in a simple way via contacts and binary inputs and additionally with the station unit. This results in a number of cabling requirements in the substation. Every vendor has its own bus for its configuration tools; for inter-bay communication you need hardwiring and binary inputs and outputs, etc. With Ethernet and IEC 61850 you now have the possibility of running all services on any device of any vendor on the same bus in parallel at the same time.

Thus all devices only need two pairs of copper cables or one pair of fiber optic cables to execute communication.

2.1 Layer 2 redundancy with RSTP

There are several redundancy algorithms available for layer 2 networks. Some are dedicated and some are standardized in the Ethernet world by IEEE. The most common redundancy protocol is the so-called RSTP (Rapid Spanning Tree Protocol).

This protocol provides the option of connecting all used Ethernet switches in a ring structure; Siemens SIPROTEC devices with optical IEC 61850 module can act in that manner due to the integrated switch function.

To achieve network redundancy one requires more than one path from source to destination. This will be achieved with the ring structure which provides the physical loop in the network design. However, if a true loop were to occur in an Ethernet network, the first broadcast frame would circulate endlessly, consuming the entire available bandwidth. This results in a so-called "broadcast storm". RSTP prevents this problem by quickly forming a logical tree network that spans all components of the network, as the name of the protocol describes. In the case of the ring structure, one of the physical interconnections between two switches will be logically switched off automatically. This backup link will be re-enabled as needed when network problems occur to restore the connectivity of all attached devices. This will be done automatically and also works with any kind of network topology.

Not just redundancy in itself is very important in substation automation systems. A fast recovery time in the event of an error is also required. The typical recovery time in a RSTP ring configuration is some 100 milliseconds up to one second. This period lasts too long for substation communication. For this reason Siemens made an extension to the RSTP algorithm. So Siemens' Ethernet module supports both versions automatically without the need to change the configuration.

Recovery times between 20 and 30 milliseconds are possible even in complex ring structures with 30 devices. These comprehensive tests were made successfully together with the Ruggedcom switches by the Siemens test laboratory with the recommended switches (RuggedCom, Hirschmann and Siemens Scalance).

2.2 Monitoring networks

As in the case of control centers, you also have the possibility of an online view of your running Ethernet devices. This is implemented via the so-called Simple Network Management Protocol (SNMP).

This common Ethernet protocol provides an online monitoring view of all Ethernet switches as well as the SIPROTEC devices. It is not just possible to view network parameters such as performance data of the device and so on; it is sometimes also possible to configure them.

2.3 Time synchronization with SNTP

The Simple Network Time Protocol (SNTP) is the common protocol in Ethernet networks for synchronizing the integrated clocks in network-connected devices. SNTP is also described in the IEC 61850 standard for distribution of time information to all participants. This will be performed by an SNTP server which is also connected to the Ethernet. This time server has an external time source, for example a DCF or GPS receiver. All other connected devices act as SNTP clients and ask the server for the right time at certain periods. All SIPROTEC 4 devices support the SNTP protocol for time synchronization. The configuration for this topic can be done directly in DIGSI. Also possible in the DIGSI Manager is a redundant clock master, so you have a higher availability of your SNTP time synchronization system. In the unlikely case of an error of the main clock master, the secondary clock master takes over the time requests of all SIPROTEC devices.

2.4 VLAN and priority tagging

With VLAN (Virtual LAN) tags you can create different sub-networks within your network. This will be performed by adding additional bits to the Ethernet frame. In this way you can separate devices in the network which are not to communicate with other devices of the same network. This is just possible with a layer 3 instance, e.g. a router. In theory, more than 4000 different VLAN segments are possible.

The three priority bits tag an Ethernet frame to transmit the frame with a higher priority than a second frame, which shall be transmitted over the same network segment. So the frame with the highest priority will be sent out first.

Both information tags, the VLAN and the Priority, are common extensions in the Ethernet world for separating and prioritizing Ethernet traffic. In the IEC 61850 standard there is also the definition that IEC 61850-compliant devices shall support this common Ethernet feature.

These features are used especially for GOOSE messages. GOOSE messages have to be transmitted very fast and with a higher priority than other types of Ethernet frames.

3. Communication network designs

Switches can be seen as a short piece of an Ethernet bus. They can be used to distribute this bus to different physical locations. If managed switches are used, they can also be configured to relieve the network traffic in certain segments of the Ethernet. Thus you can implement collision-free data transmission.

With respect to the existing cabling infrastructure, the cost situation and the need for highly available networks, several network designs are necessary and possible. This article cannot describe all the different variants; the three most common structures are described here. Different modifications of these are possible, of course.

The last one is only possible with the optical Ethernet modules. Each of these modules contains an integrated switch function, with the result that the SIPROTEC devices can be connected to each other directly in a daisy chain connection.

An optical fiber Ethernet ring with special switches (providing ring redundancy by means of 'rapid spanning tree' or similar mechanisms) is used for such cases. In this way switches can be used to distribute the

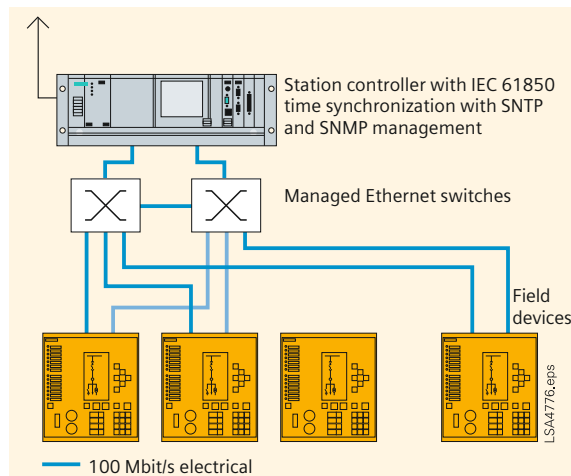

Fig. 29 Station bus in a star structure

Ethernet backbone (Ethernet bus) to different physical locations.

Such an Ethernet ring works on the n-1 basis. If there is a communication interruption, then the switches will automatically reconfigure the ring in such a way that no communication is lost.

To guarantee that all devices work together properly we have tested in our system test department a system with many IEC 61850 IEDs to provide our customers with fast and reliable communication. In the meantime there are more than 1000 substations running with IEC 61850 worldwide. Some customers have systems with more than 200 devices running well without interruptions.

3.1 Radial Ethernet connections (star structure)

Fig. 29 shows IEDs connected to two switches which would also be possible for station units.

This configuration can normally be used if all Ethernet devices are physically relatively close to each other; with fiber optical connections longer distances are also possible.

This design can be chosen if electrical Ethernet modules are to be used. All SIPROTEC devices and station units can be connected dual-armed to the network. Special redundancy mechanisms such as RSTP are not necessary here, because no loop exists in this network. This offers redundancy if one of the switches is off duty and connection redundancy for all attached devices as well. For this kind of network design less effort is involved for the configuration of the Ethernet switches.

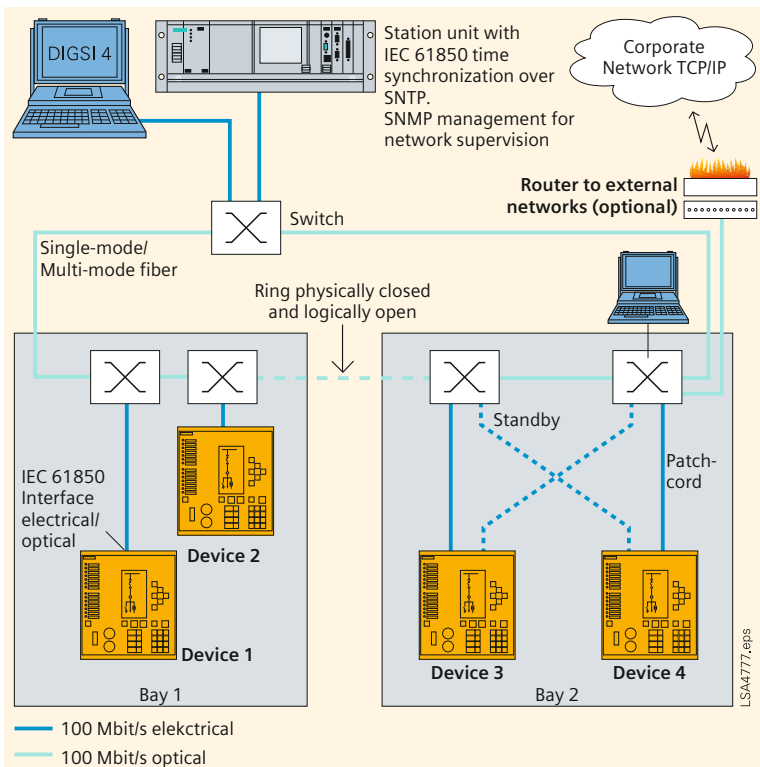

Fig. 30 Station bus in a ring structure with external switches

3.2 Ethernet ring with Ethernet switches

Fig. 30 shows an Ethernet ring made with external switches. The layer 2 redundancy mechanism opens the ring logically so there are no circulating telegrams. In the event of errors on one switch or a broken connection between two switches the logically opened connection will be established automatically in a few milliseconds so that communication is still possible between all devices. The connections between the switches can be realized either with multi-mode fiber or with single-mode fiber, depending on the existing cabling infrastructure and the used switches.

Also possible with this design are interconnections between different locations. All you need is an adequate fiber connection to interconnect the different locations. Thus distances up to 100 km are possible.

In one ring up to 30 switches are possible. With proprietary enhancements of RSTP you can build up rings with up to 80 switches. The amount of IEDs which can be connected to one switch is just limited by the number of

physical connection ports (typically six IEDs or more per switch).

All SIPROTEC devices and station units can be connected dual-armed to the network; both electrically and optically are possible. This offers redundancy in case of malfunction of one of the switches and connection redundancy for all attached devices as well. In the dual-armed design one of the two connections is always active, the second is on standby. In case of link failures, the standby connection will be activated within less than five milliseconds, so that communication with the device is still possible.

Additionally the connections between the switches can be realized with two separate connections, these two connections will be combined via "link aggregation", which means you can double the ring bandwidth and also have an additional connection redundancy.

A notebook for DIGSI configuration and also any other device can be attached to the network. The DIGSI-PC should be connected to a switch port which does not generate a so called "link loss" alarm while disconnecting the PC after the configuration process. This alarm can be activated or disabled at every switch port within the switch configuration tool.

3.3 Ethernet ring with SIPROTEC IEDs

Fig. 31 shows the preferred configuration with the greatest benefits. Just one or two external switches are necessary. This is possible on account of the unique integrated switch function in the optical Ethernet module. In this way you can connect up to 30 SIPROTEC devices in one ring. If you need more you just have to create a second ring, which can be connected to the same switches (see also Fig. 32).

The optical module forwards all telegrams in wire speed without any delay; just the relevant frames for the receiving device will be picked up from the station bus.

The optical Ethernet modules fully support the layer 2 redundancy mechanism RSTP, so you have the same redundancy features as with external switches. Additionally and especially together with switches from Ruggedcom the reconfiguration times after failures were optimized. This design was tested by our system test and is applied for a reliable and user-friendly communication structure.

All SIPROTEC devices are connected dual-armed to the network in this way. Both connections are active at the same time.

All necessary components with electrical ports can be connected to the external switches. A notebook for DIGSI 4 configuration can be attached to the network at the external switches (see Fig. 31).

Fig. 32 shows that not just one ring is possible. This design allows you to create a system with up to 27 SIPROTEC devices. If more devices are in use, you can simply create a second ring with 27 additional devices, and so on and so on. This picture shows very clearly one of the benefits of the optical Ethernet module: you just need two external switches for a highly available redundant IEC 61850 Ethernet network.

This design provides you with cost advantages, a drastic reduction of external components, a simple configuration with fewer components in the network and a high availability due to reduction of external components.

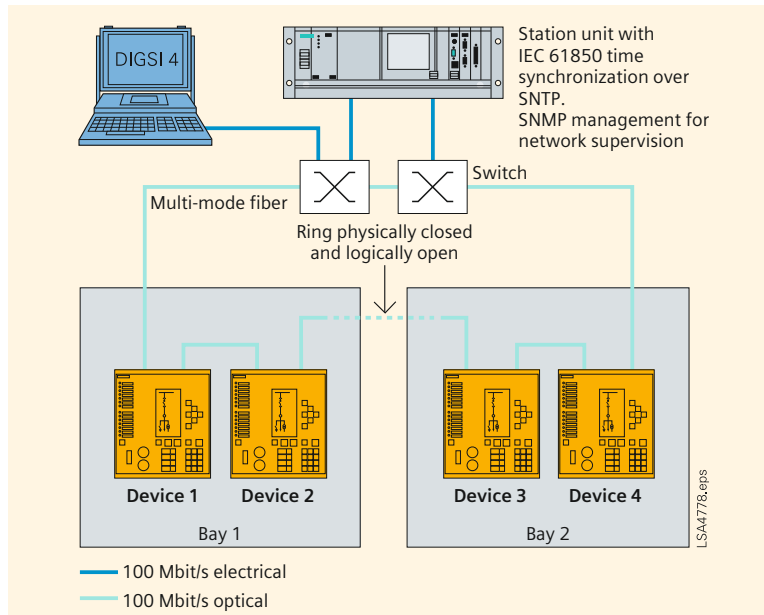

Fig. 31 Station bus with SIPROTEC devices in a ring structure

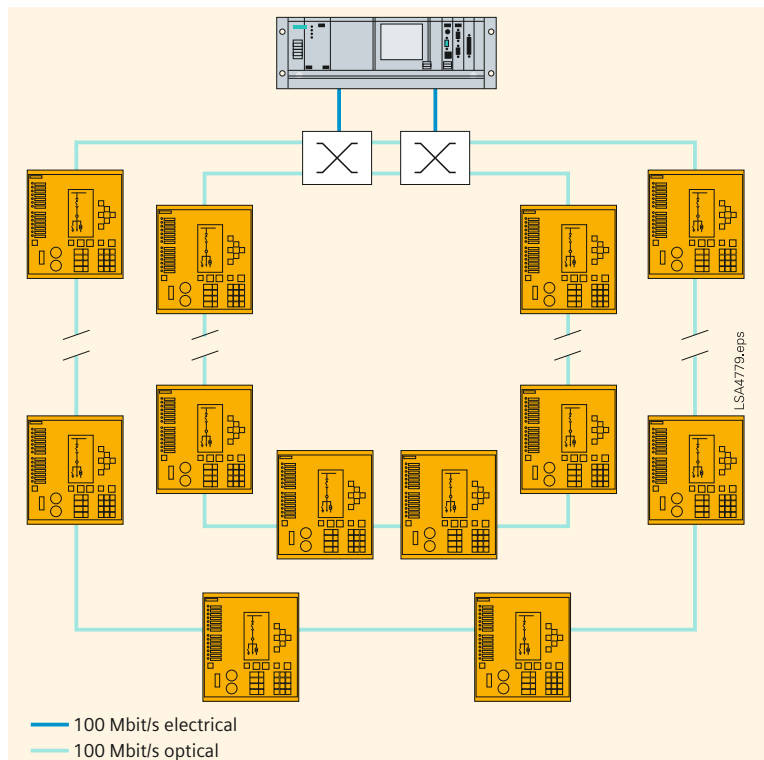

Fig. 32 Station bus with SIPROTEC devices in a double ring structure

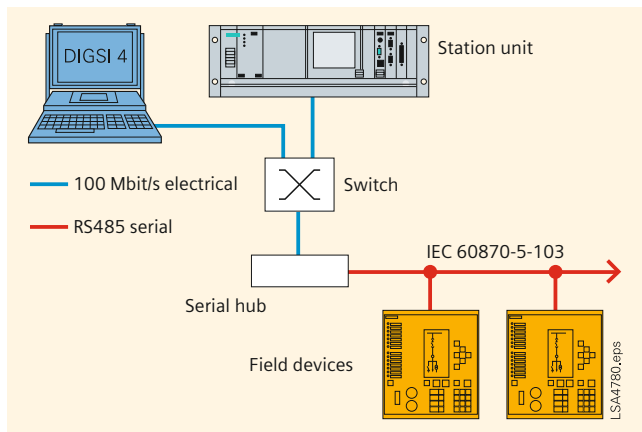

Fig. 33 Connecting non-IEC61850 IEDs to the station bus

3.4 Connecting non-IEC61850 IEDs with serial interfaces

If non-IEC 61850 IEDs need to be connected to the station unit, then it is advisable to use a serial hub. In the station unit these IEDs may then be configured to the same interface (e.g. communication port 3). Even in redundant station unit configurations serial hubs can be integrated. In the master station unit this interface will be enabled and in the standby station unit this interface will be disabled. Once switchover occurs, these interfaces will be toggled. At first the interface of the master station unit will have to be switched off, subsequently the interface of the standby station unit will have to be enabled. Communication to the relevant IEDs will have to be interrupted for a short period of time. It will be necessary to use the automation and OPC interface for this implementation.

Serial hubs can also be used if you want to configure a non-IEC 61850 SIPROTEC device with DIGSI via the Ethernet. In this case the path of communication is implemented in the DIGSI PC with virtual COM ports. This virtual COM port is assigned to the IP address of the serial hub in the network. In this way you have a kind of point-to-point connection between DIGSI and the SIPROTEC device. The bit stream of the serial connection will be wrapped up in the Ethernet frames; every Ethernet frame acts as a container for transporting the information. At the receiver side, the information will be unloaded out of the Ethernet frames and reorganized for a serial connection to destination. All serial communication will be "tunnelled" through the Ethernet.

4. Summary

Hardware and software requirements for typical redundancy architectures were discussed and advantages of the different design were explained. The described configurations are recommended because they are successfully tested in comprehensive test scenarios by our Siemens Test laboratory.

The highest benefit will be achieved with the optical Ethernet modules when working in switch mode in one or more ring structures. For this configuration just two or a few external switches are necessary. All SIPROTEC devices are automatically connected in a ring structure to the network with both connections in active mode.

The integrated switch function of the optical Ethernet modules in the SIPROTEC device reduce the required number of external devices, which decreases the configuration effort to a minimum and makes the configuration as simple as possible.

In the event of errors or failures in the ring, reconfiguration times are between a very fast 20 and 30 milliseconds.

IEC Interoperability, Conformance and Engineering Experiences

1. Overview

The interoperability tests carried out in the past and the numerous customer projects highlight the special importance of the standardized configuration language SCL (Substation Configuration Description Language).

IEC 61850 is the global communications standard for station automation. The conditions that must be fulfilled so that the engineering functions perfectly not only in equipment from one manufacturer but also in so-called mixed configurations can be identified in the interoperability tests carried out in various regions of the world.

2. Introduction

The last part of the IEC 61850 standard series, the part relating to the requirements for conformity with the standard, was published in May 2005. But even before this date, in November 2004, the first IEC 61850-compliant substation in the world with equipment from Siemens went into service in Winznaschachen (ATEL Switzerland). By end of 2010, Siemens carried out projects for more than 1000 switching stations with IEC 61850-compliant communication between devices.

The advantages of IEC 61850 were already apparent in these first substations. It was also clear that certain preconditions had to be met, for example conformity with standards and standardized engineering.

Conformity of the communications interfaces of the individual device types with the standard is checked and certified (Fig. 34) on behalf of the manufacturers by an independent test laboratory, for example KEMA in the Netherlands, see bibliography on page 41, reference [1].

This tests laboratory was accredited by the international user organization of the IEC 61850, the UCA international, see bibliography, ref. [2]. It works according to test plans that have been drawn up jointly with the user organization. Valuable experience has been gathered in the first tests and certifications of equipment with IEC 61850 interface which indicates an extremely high quality



Fig. 34 Conformity certificate for SIPROTEC 4 device 7SJ64

of the products and of the certification processes.

Another step for ensuring interoperable solutions is the implementation of so-called interoperability tests which are initiated, for instance, by the user organization UCA international or by individual users, that is to say electric utilities. Important tests included the interoperability demonstrations at the CIGRE 2004 and 2006 in Paris and in the exhibition on the occasion of the Western Protective Relay Conference in Spokane (USA) in October 2005; see Fig. 35 on next page.

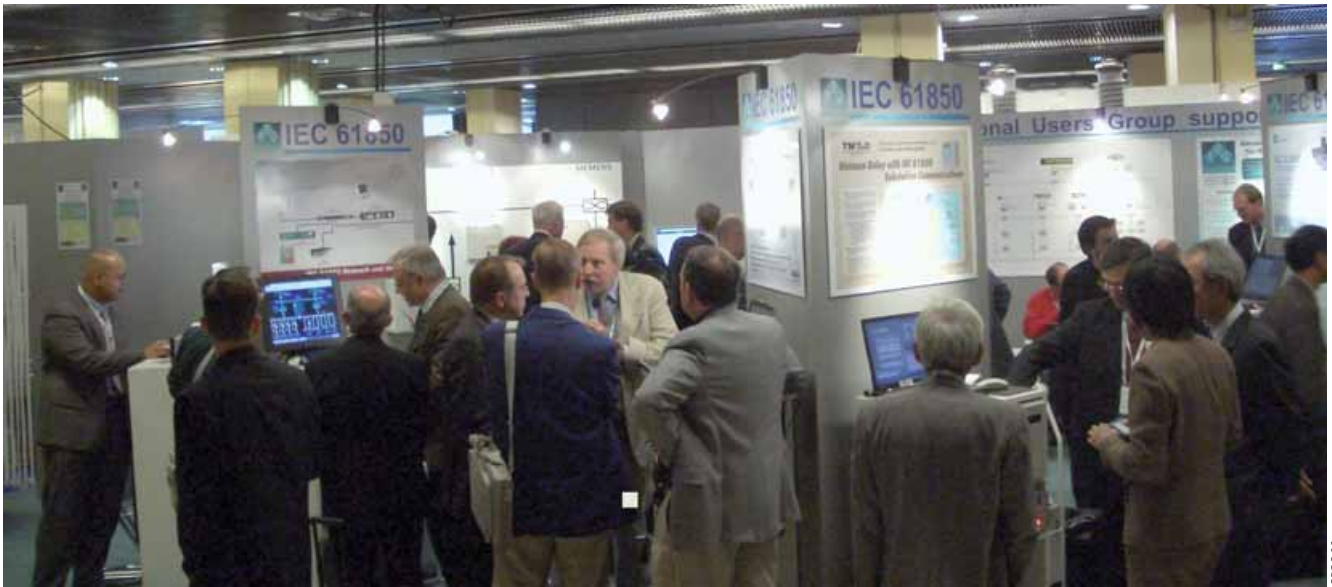

Fig. 35 CIGRE in Paris

■ 3. IEC 61850-6 engineering process

Part 6 of standard IEC 61850 defines the Substation Configuration Description Language (SCL) for a station automation system (SAS) [3]. This is the core element of the engineering according to IEC 61850. The SCL language is not a programming language like Java, C++ or Assembler but is a system description language based on XML. This means that a way has been found of describing the communications and object model of a station automation system in machine-readable form using the XML instruction set, see bibliography on page 41, ref. [4].

The IED and the system configuration of a station automation system are implemented in the engineering process in accordance with IEC 61850-6.

The actual parameterization of the selected IEDs (Intelligent Electronic Devices) is implemented with the vendor- and equipment-specific IED configuration tools (IED Configuration Tools). The DIGSI 4 tool is used for SIPROTEC bay controllers and protection devices. This tool is also used to create and adapt the ICD (IED capability description) files, see bibliography, ref. [5].

The description files of the IEDs are further processed by a system configuration tool in the system engineering. The result of the engineering in the system configuration tool is a description file for the configuration of the station automation system (SCD - Substation Configuration Description).

1) XML- Extensible Markup Language, defined by the W3C (World Wide Web Consortium)

The file generated by the system configuration tool is then re-imported the IED configuration tools. The individual IED configuration tools read out the configuration parameters that are needed for the particular device.

The advantage of the engineering procedure described consists in the vendor-neutral and automated exchange of the configuration data of both the IEDs (importing of the IED file into the system configuration tool) and the communication system (importing the system file back into the IED configuration tools). Since vendor-specific tools are used here as a general rule, it goes without saying that only SCL-compliant files can be processed without error.

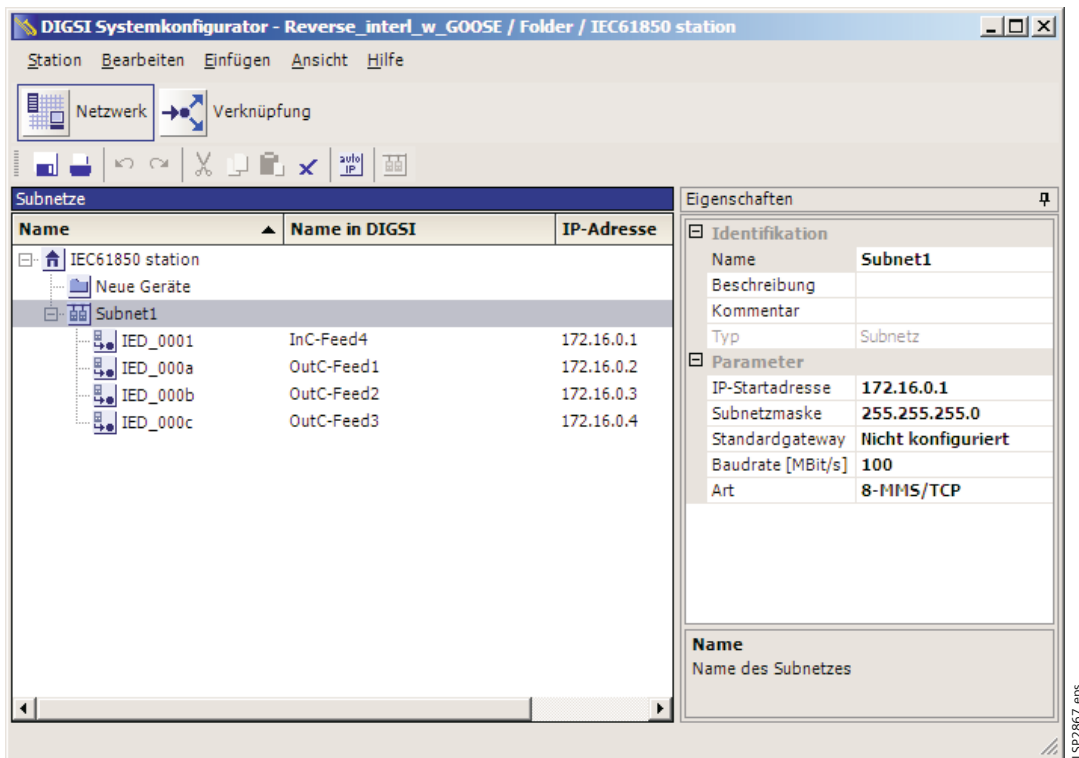

Fig. 36 IEC 61850 system configuration tool in DIGSI 4 tool

■ 4. System planning and system integration

The system planner and the system integrator of a substation have a particular responsibility. The station automation system is designed and developed during the system planning. The individual device types are selected in this phase, which includes matching the data models (what data is available) and the necessary communication services (how the data is transmitted). That depends on the planned application functions.

For example, all relevant data relating to the switching states (e.g. circuit-breaker on/off, disconnector open/closed, grounding switch open/closed) must be made available for the station interlocking test.

This should also be carried out as promptly as possible to each change of state. One transmission service that fulfils the time requirements with a high degree of reliability is the GOOSE¹⁾ service of the IEC 61850.

This is a spontaneous/cyclical, object-oriented multicast transmission at Etherlink level. This firstly ensures a short transmission time to a large number of recipients and secondly also guarantees that the latest message changes are transmitted to all GOOSE stations.

In order to enable the application functions to use the GOOSE service, the service must be implemented in every participating device. The standard does not stipulate which services are implemented in the equipment of the various vendors. That is the decision of the manufacturers, and selection of compatible equipment is the responsibility of the system planner.

The parameters of the special application functions are set during system integration. This process is implemented as described above with the aid of IED configuration and system configuration tools. Apart from the communication parameters, parameters must also be set for evaluating and using the individual data. In the exemplary application described above (station interlocking test), it is necessary to include not only the switching states of the disconnectors, earth grounding switches and circuit-breakers in the evaluation logic but also the so-called quality of this data (valid, blocked, invalid, replaced, etc.). The actual implementation of the function logic of the interlocking test does not form part of the contents of the communications standard IEC 61850. That is the task of the function software of the individual devices.

Checking the communication capabilities and functionality of the equipment for the planned applications is the responsibility of the system planners and system integrators.

1) GOOSE – **G**eneric **O**bject-**O**riented **S**ubstation **E**vent

■ 5. Certification of standard-compliant devices

A useful aid for the user of IEC 61850-compliant equipment is the check for conformity with the standard which is confirmed by the KEMA certificate. As a precondition for this test, the following documents and files documenting compliance with standard IEC 61850 must be provided by the manufacturers:

- > MICS – Model Implementation Conformance Statement (declaration by the manufacturer with respect to the implemented data model)
- > PICS – Protocol Implementation Conformance Statement (declaration by the manufacturer with respect to the implementation of the protocol and the transmission services).
- > PIXIT – Protocol Implementation Extra Information for Testing
- > ICD – IED Capability Description (engineering process file relating to the capability of the IED).

These documents are important sources of information for the system planners and system integrators of station automation systems because they provide information about the status and scope of implementation of the IEC 61850 standard.

There are a number of potential problems that can occur in the case of IEC 61850-compliant communication between devices.

- The engineering files provided for the equipment (ICD) are not valid.

The substation Configuration Description Language (SCL) is based on XML and thus displays the characteristic that files created with it can be checked for compliance with the SCL rules against a so-called XML schema. This is implemented with the aid of a validator, a software program that carries out these tests. If the ICD file is not valid it naturally cannot be imported and processed in the system configuration tool and consequently communication between the associated devices within the SAS is also not possible. DIGSI operating program exports SCL: description files based on strict application of the IEC 61850 scheme.

- Implemented transmission services of different devices are not compatible.

The standard does not stipulate which transmission services are to be implemented in the bay devices (protection and control devices) and in the station control unit. However, there are mandatory rules as far as dependence between equipment is concerned, particularly with regard to the interaction between station control unit and bay controllers. For example, a protection device that wants to dispose of its alarms, warnings and status messages per buffered reporting (buffered message transmission via TCP/IP) in its capacity as server should be connected to a station control unit with the same client functionality. If the client of the station control unit "only" offers the unbuffered transmission service this causes a conflict in the engineering. Sound technical support by Siemens employees during preparation and specification of the substation automation system ensures that only devices that have passed interoperability tests are deployed.

- Use of private data objects.

The use of non-standard-compliant data objects is not forbidden by the standard. They are identified via a dedicated name space. Naturally, it is not possible to achieve interoperability in this way because only the manufacturer of the device concerned knows the designations and significance of the data. Full modeling of the data with the resources of IEC 61850 is a basic requirement for utilizing the advantages of the standard. Only data classes from the IEC 61850 model are used for Siemens SAS, bay control units and protection devices.

■ 6. Summary

Requirements for the implementation and application of IEC 61850 can be deduced as follows:

- Interoperability tests will diminish the risk of interoperability problems between devices in the initial phase of the global rollout of the standard in which a constant stream of new equipment types from the manufacturers are equipped with IEC 61850. This applies particularly when new equipment types are connected together for the first time before they have been certified for compliance with the standard.
- Engineering tools are not yet standardized in the standard. An important aspect for good user-friendliness is to restrict the display of parameters for the user to those needed for the solution of the problem in hand.
- Testing for standard validity (validation) of the engineering files (ICD, SCD, SSD and CID) will facilitate working with the data whenever data is imported into a configuration tool. Errors are detected early on and consequential faults can be avoided.

Bibliography and reference tips:

- [1] KEMA Netherlands – <http://www.kema.com>
- [2] UCA International Users Group – <http://ucausersgroup.org>
- [3] IEC 61850-6 Communication networks and systems in substations – Part 6: Configuration description language for communication in electrical substations related to IEDs. Geneva/Switzerland: Bureau Central de la Commission Electrotechnique
- [4] Etz-Report 34 "Offene Kommunikation nach IEC 61850 für die Schutz- und Stationsleittechnik" (Open communication to IEC 61850 for protection devices and station control systems), 2004, K.-H.Schwarz et al., Article 11: Engineering und Konfiguration von Schaltanlagen-Leittechnik (Engineering and configuration of switchgear control technology), Dr. W.Wimmer, H.Dawidczak
- [5] SIPROTEC. Siemens AG, Energy Sector Power Distribution Division Energy Automation (E D EA), Nuremberg: <http://siemens.siprotec.de>

IEC Browser – A Powerful Test Tool for IEC 61850

■ 1. IEC Browser – A Powerful Test Tool for IEC 61850

The IEC browser was developed for SICAM PAS as a test tool. The PC program acts as an IEC 61850 client and, in online mode, represents all data objects of an IEC 61850 server, e.g. a SIPROTEC 4 device. Just like with an Internet browser, you can connect to the IEC 61850 server, which runs on an EN 100 Ethernet module of a SIPROTEC 4 device, read all the data objects, and even change some data objects. The left window shows the logical devices and logical nodes of a server in a tree structure. The right window shows the values of the data objects you have selected in the left window.

For installation the IEC browser freeware is available free of charge on the DIGSI program CD (V 4.80 and newer).

First import the ICD files of the individual devices of an IEC 61850 station. Then connect to the devices that are connected to the same network. Even more conveniently, you can load the completely configured station, i.e. its SCD files. Here, all IP addresses are stored, of course, and clicking "Connect" is all you need to do to establish the connection.

It is easy to find what you are looking for: the IEC 61850 data objects are clearly organized and displayed in a tree structure together with their familiar descriptions from the device context. In AutoRefresh mode, changes to the IEC 61850 object list are displayed immediately without manual triggering.

Furthermore, it is possible to configure dynamic reports that are then spontaneously sent to the browser by the device, if data objects have changed. These reports can be changed or deleted directly from the IEC browser without first having to create them in the system configurator. But the reports and the GOOSE applications that were configured in the system configurator are also displayed by the browser in online mode. You can change controllable data objects using the IEC browser: This makes it possible for commands to be transferred to the device as a test.

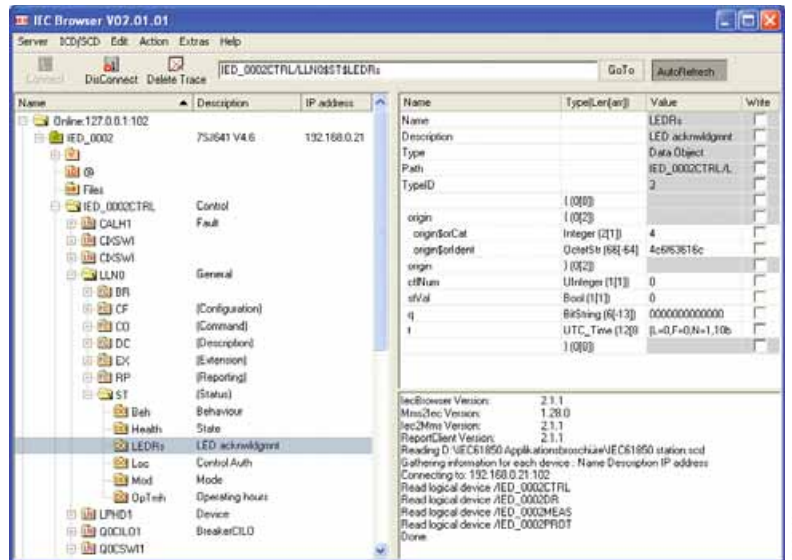

Fig. 37

The IEC browser is a powerful tool for analyzing and testing the IEC 61850 client – server communication. This program is free of charge for every DIGSI user. It can be operated in parallel to DIGSI so that changes to the IEC 61850 parameterization are directly traceable in the browser.

Exclusion of liability

We have checked the contents of this manual for agreement with the hardware and software described. Since deviations cannot be precluded entirely, we cannot guarantee that the applications described will function correctly in any system.

Copyright

Copyright Siemens AG 2010.
All rights reserved

The reproduction, transmission or use of this document or its contents is not permitted without express written authority. Offenders will be liable for damages. All rights, including rights created by patent grant or registration of a utility model or design, are reserved.

Registered trademarks

SIPROTEC, SICAM and DIGSI are registered trademarks of SIEMENS AG. The other names appearing in this manual may be trade names the use of which by third parties for their own purposes may infringe the rights of the owners.

Published by and copyright © 2010:
Siemens AG
Energy Sector
Freyeslebenstrasse 1
91058 Erlangen, Germany

Siemens AG
Energy Sector
Power Distribution Division
Energy Automation
Postfach 48 06
90026 Nuernberg, Germany
www.siemens.com/energy/siprotec

For more information, please contact our
Customer Support Center.
Phone: +49 180 524 70 00
Fax: +49 180 524 24 71
(Charges depending on provider)
E-mail: support.energy@siemens.com

Order No. E50001-K4455-A101-A2-7600
Printed in Germany
Dispo 06200, c4bs 7442
KG 12.10 1.0 48 En
003600/30633

Printed on elementary chlorine-free bleached paper.

All rights reserved.
If not stated otherwise on the individual pages of this
catalog, we reserve the right to include modifications,
especially regarding the stated values, dimensions and weights.
Drawings are not binding.
All product designations used are trademarks or product
names of Siemens AG or other suppliers.
If not stated otherwise, all dimensions in this
catalog are given in mm.

Subject to change without prior notice.
The information in this document contains general
descriptions of the technical options available, which
may not apply in all cases. The required technical
options should therefore be specified in the contract.